

ARTESYN CONFIGURABLE NeoPower

Up to 4000 W



PRODUCT DESCRIPTION

Advanced Energy’s Artesyn NeoPower (NP) configurable AC-DC power supplies provide high power density as either a programmable voltage or current source. The NeoPower features an intuitive software interface and user configurable modules to enable fast prototypes. Modules can be connected in series and parallel with the configurable buss bar system to enable 1,000’s of output combinations.

The NeoPower is certified for both industrial and medical safety approvals, including compliance of the SEMI F47 standard. The NeoPower supports digital communication with MODBUS RTU for control, monitoring and configuration.

SPECIAL FEATURES

- Short circuit protection
- Over voltage protection (OVP)
- Over current protection (OCP)
- Over temperature protection (OTP)
- Active power factor correction
- Output on/off control
- Fan speed control
- Power good signal
- Active current share
- Remote voltage sense
- Support MODBUS RTU digital communication
- Support PMBUS and CANOPEN with PowerPro dongle
- Medical BF rated
- End user installable modules (no hi-pot or safety certifications required to install modules)
- 5-year manufacture’s warranty

SAFETY

- IEC/EN 62368-1
- UL 62368-1
CSA C22.2 No. 62368-1
- IEC/EN 60601-1
- ANSI/AAMI ES 60601-1
CSA C22.2 No. 60601-1
- CE mark (LVD+RoHS)
- CB certificate and report
- CCC/CQC

AT A GLANCE

Total Power

Up to 4000 W

Input Voltage

90 to 264 Vac

Single Phase

of Outputs

Up to 8



TABLE OF CONTENTS

Section 1	Model Numbers	5
1.1	Ordering Information	5
1.2	Case Selection Table	6
1.3	Module Selection Table	6
1.4	Output Voltage Code Table	6
1.5	Parallel and Series Connection Table	7
Section 2	Electrical Specifications	8
2.1	Absolute Maximum Ratings	8
2.2	Input Specifications	9
2.3	Output Module Specifications	10
2.4	Output Specifications - Voltage Source (VS) Mode	11
2.5	Output Specifications - Current Source (CS) Mode	13
2.6	System Timing Specifications	14
2.7	System Timing Diagram	15
2.8	Performance Curves - Case	16
2.9	Performance Curves - Modules	19
2.10	Protection Function Specifications	29
Section 3	Mechanical Specifications	31
3.1	NP05 Case Mechanical Outlines	31
3.2	NP08 Case Mechanical Outlines	32
3.3	1 Slot Single Output Medical Module Mechanical Outlines	33
3.4	1 Slot Single Output Low Noise Module Mechanical Outlines	34
3.5	1 Slot Dual Output Module Mechanical Outlines	35
3.6	Connector Definitions - Case	36
3.7	Connector Definitions - Single Output Modules	37
3.8	Connector Definitions - Dual Output Modules	37
3.9	Power/Signal Mating Connectors and Pin Types	38
3.10	LED Indicator Definitions - Case	39

TABLE OF CONTENTS

3.11 LED Indicator Definitions - Modules	39
Section 4 Environmental Specifications	40
4.1 EMC Immunity	40
4.2 Safety Certifications	41
4.3 EMI Emissions	42
4.4 Operating Temperature	43
4.5 Storage and Shipping Temperature	43
4.6 Altitude	43
4.7 Humidity	43
4.8 Forced Air Cooling	43
4.9 Acoustic Noise	44
4.10 Vibration	44
4.11 Shock	45
Section 5 Power and Control Signal Descriptions	46
5.1 AC Input Connector	46
5.2 Case Signal Connector - J1	46
5.3 Case Connected Power Bus Connector - J2	48
5.4 Module Signal Connector - J106	48
Section 6 MODBUS Specifications	51
6.1 MODBUS General Instructions	51
6.2 Case Supported Command List	54
6.3 Module Supported Command List	61
6.4 Black Box	66

TABLE OF CONTENTS

Section 7	Application Notes	70
7.1	Mode of Operation	70
7.2	Output Adjustability and Programmability	71
7.3	Current Sharing	80
7.4	Output Ripple and Noise Measurement	81
Section 8	Record of Revision and Changes	82

SECTION 1 MODEL NUMBERS

1.1 Ordering Information

NPWWXYZ	-	XYZO	-	XY	-	XYZ	-	A	-	0	-	XXX
①		②		③		④		⑤		⑥		⑦

①	Case Code	<p>WW: Number of Slots - Case Size 05 = 5 Slots (2.5" x 5" x 11") 08 = 8 Slots (2.5" x 8" x 11")</p> <p>X: Input Voltage Range W = Wide range 90 to 264 Vac H = High line L = Low line</p> <p>Y: Input Phase 1 = Single phase</p> <p>Z: Input Line A = AC input</p>
②	Module Options Code	<p>X: Number of Slots for Module 1 = 1 slot, single O/P 2 = 1 slot, dual O/P</p> <p>Y: Module Type L = Low Noise M = Medical</p> <p>Z: Voltage Codes See "Output Voltage Code Table"</p> <p>O: Option Codes for Single Output Module (*Use the output 2 voltage code for dual output module) 0 = DVS, Module ON 1 = DCS, Module ON 2 = AVS, Module ON 3 = ACS, Module ON 4 = DVS, Module OFF 5 = DCS, Module OFF 6 = AVS, Module OFF 7 = ACS, Module OFF Z = Option defined in MOD-I</p>
③	Case Option Codes	<p>X: Case Options 0 = No options 1 = Reverse air Z = See MOD-I</p> <p>Y: Configuration Code 0 = Shipped from AEI cases/modules C = AEI factory configured/tested</p>
④	Parallel/Series Code	See "Parallel and Series Connection Table" 000 = No series/parallel
⑤	Software Code	A = Standard B = Non standard voltage
⑥	Communication Bus	0 = Standard MODBUS RTU Z = See MOD
⑦	Modification Code	AEI assigned code to track modification made from the standard design CC = Conformal coating RG = Ruggedized

SECTION 1 MODEL NUMBERS

1.2 Case Selection Table

Case	Part Number	Description	Status
NP05W1A	83-105-0001W	2400W Case, 1-Phase	Released
NP08W1A	83-108-0001W	4000W Case, 1-Phase	Released

1.3 Module Selection Table

Module	Part Number	Description	Status
1S 0005M	83-011-0005M	1 Slot 5V Medical, 280W	Released
1S 0012M	83-011-0012M	1 Slot 12V Medical, 400W	Released
1S 0015M	83-011-0015M	1 Slot 15V Medical, 400W	Released
1S 0024M	83-011-0024M	1 Slot 24V Medical, 400W	Released
1S 0048M	83-011-0048M	1 Slot 48V Medical, 400W	Released
1D 2424M	83-021-2424M	1 Slot 24V-24V Medical, 400W Dual Output	Pre-Release

1.4 Output Voltage Code Table

Voltage	Code	Voltage	Code	Voltage	Code	Voltage	Code
2 V	A	5.5 V	G	14 V	M	30 V	S
2.2 V	B	6 V	H	15 V	N	33 V	T
3 V	C	8 V	I	18 V	O	36 V	U
3.3 V	D	10 V	J	20 V	P	42 V	V
5 V	E	11 V	K	24 V	Q	48 V ¹	W
5.2 V	F	12 V	L	28 V	R	54 V	X

Note 1 - Maximum output voltage trim of 48V 1slot module variant is up to 57.6V. Please contact Advanced Energy for the modification availability of an output voltage higher than 57.6V.

SECTION 1 MODEL NUMBERS

1.5 Parallel and Series Connection Table

Case	Start Slot	Start Slot Code (X)	# Slots Connected Across (Y)	Parallel/Series (Z)	Description
NP08	1	1	2	P/S	1&2
NP08	2	2	2	P/S	2&3
NP08	3	3	2	P/S	3&4
NP08	4	4	2	P/S	4&5
NP08	5	5	2	P/S	5&6
NP08	6	6	2	P/S	6&7
NP08	7	7	2	P/S	7&8
NP08	1	1	3	P/S	1&2&3
NP08	2	2	3	P/S	2&3&4
NP08	3	3	3	P/S	3&4&5
NP08	4	4	3	P/S	4&5&6
NP08	5	5	3	P/S	5&6&7
NP08	6	6	3	P/S	6&7&8
NP08	1	1	4	P/S	1&2&3&4
NP08	2	2	4	P/S	2&3&4&5
NP08	3	3	4	P/S	3&4&5&6
NP08	4	4	4	P/S	4&5&6&7
NP08	5	5	4	P/S	5&6&7&8
NP08	1	1	5	P/S	1&2&3&4&5
NP08	2	2	5	P/S	2&3&4&5&6
NP08	3	3	5	P/S	3&4&5&6&7
NP08	4	4	5	P/S	4&5&6&7&8
NP08	1	1	6	P/S	1&2&3&4&5&6
NP08	2	2	6	P/S	2&3&4&5&6&7
NP08	3	3	6	P/S	3&4&5&6&7&8
NP08	1	1	7	P/S	1&2&3&4&5&6&7
NP08	2	2	7	P/S	2&3&4&5&6&7&8
NP08	1	1	8	P/S	1&2&3&4&5&6&7&8

SECTION 2 ELECTRICAL SPECIFICATIONS

2.1 Absolute Maximum Ratings

Stress in excess of those listed in the “Absolute Maximum Ratings” may cause permanent damage to the power supply. These are stress ratings only and functional operation of the unit is not implied at these or any other conditions above those given in the operational sections of this TRN. Exposure to any absolute maximum rated condition for extended periods may adversely affect the power supply’s reliability.

Table 1. Absolute Maximum Ratings						
Parameter	Models	Symbol	Min	Typ	Max	Unit
Input Voltage	All models	$V_{IN,AC}$	90	-	264	Vac
Maximum Output Power	Low Line Input	$P_{O,max}$	-	-	2000	W
	High Line Input		-	-	4000	W
Isolation Voltage ¹ - AC	Input to Output	All models	-	-	5000	Vac
	Input to Earth		-	-	1800	Vac
	Output to Earth		-	-	1800	Vac
Isolation Voltage ¹ - DC	Input to Output	All models	-	-	7000	Vdc
	Input to Earth		-	-	2500	Vdc
	Output to Earth		-	-	2500	Vdc
Ambient Operating Temperature	All models	T_A	0	-	70 ²	°C
Storage Temperature	All models	T_{STG}	-40	-	85	°C
Humidity (non-condensing)	Operating	All models	20	-	90	%
	Non-operating	All models	10	-	95	%
Altitude ³	Operating	All models	-	-	3,000	meters
	Non-operating	All models	-	-	9,144	meters
MTBF ⁴	All models		200k	-	-	hours
E-cap Life ⁵	All models		5	-	-	years

Note 1 - The duration for the hi-pot voltage is 60s.

Note 2 - Forward fan configuration only. 0 to +50°C: full performance, -20°C startup, 50 to +70°C: output power derated.

Note 3 - Forward fan configuration only.

70°C at sea level - 85% derated output power

50°C at 3000 meters above sea level - 90% derated output power

70°C at 3000 meters above sea level - 75% derated output power

Note 4 - It's calculated with Telcordia specifications at 25°C ambient, nominal input and 100% load.

Note 5 - It's calculated under 35°C ambient and 100% load.

SECTION 2 ELECTRICAL SPECIFICATIONS

2.2 Input Specifications

Table 2. Input Specifications							
Parameter	Condition	Symbol	Min	Typ	Max	Unit	
Operating Input Voltage, AC	Low Line	All	$V_{IN,AC}$	90	100/120	132	Vac
	High Line			180	200/240	264	Vac
Input AC Frequency	All	$f_{IN,AC}$	47	50/60	63	Hz	
Maximum Input Current	$I_O = I_{O,max}$ $I_{SB} = I_{SB,max}$	$I_{IN,max}$	-	-	27	A	
Standby Input Current ($V_O = \text{Off}$, $I_{SB} = 0A$)	All	$I_{IN,standby}$	-	0.5	-	A	
Standby Input Power ($V_O = \text{Off}$, $I_{SB} = 0A$)	All	$P_{IN,standby}$	-	50	-	W	
No Load Input Current ($V_O = \text{On}$, $I_O = 0A$, $I_{SB} = 0A$)	All	I_{IN,no_load}	-	1	-	A	
No Load Input Power ($V_O = \text{On}$, $I_O = 0A$, $I_{SB} = 0A$)	All	P_{IN,no_load}	-	100	-	W	
Voltage Dips and Interruptions	$I_O = I_{O,max}$		Meet SEMI F47-0706, 53, 58, S14 at nominal input voltages				
Harmonic Line Currents	$I_O = I_{O,max}$	THD	Meet EN61000-3-12				
Power Factor	$I_O = 10\%I_{O,max}$ $I_O = 20\%I_{O,max}$ $I_O = 50\%I_{O,max}$ $I_O = 80\%I_{O,max}$ $I_O = 100\%I_{O,max}$		0.90	-	-		
			0.95	-	-		
			0.95	-	-		
			0.99	-	-		
			0.99	-	-		
Inrush Current	$V_{IN,AC} = 264Vac$		-	-	80 ¹	A	
Input Leakage Current - Industrial	All		-	-	2.5	mA	
Input Leakage Current - Medical BF	Earth (NC)		-	-	0.5	mA	
	Earth (SFC)		-	-	1.0		
	Touch/Patient (NC)		-	-	0.1		
	Touch/Patient (SFC)		-	-	0.5		
PFC Switching Frequency	Boost Interleave Converter	$f_{SW,PFC}$	-	70	-	kHz	
Turn-on Voltage	All	$V_{IN,AC}$	85.2	87.0	88.8	Vac	
Turn-off Voltage	All	$V_{IN,AC}$	79.3	81.0	82.7	Vac	
Operating Efficiency ² @ 25°C	$V_{IN,AC} = 240Vac$	η	-	90.0	-	%	

Note 1 - Any additional inrush current surges or spikes in the form of AC cycles or multiple AC cycles greater than 10ms, and less than 150ms, must not exceed 25A peak. Short pulses (<300µs) caused by X caps are not considered.

Note 2 - Tested with NP08W1A case at 240Vac input and populated with 8 x 48V modules, 5V standby at no load.
Contact support for efficiency curve for a configured model.

SECTION 2 ELECTRICAL SPECIFICATIONS

2.3 Output Module Specifications

Table 3. Output General Specifications							
Parameter		Condition	Symbol	Min	Typ	Max	Unit
Continuous Output Power	1S 0005M/L	All	P_O	-	-	280	W
	1S 0012M/L			-	-	400	
	1S 0015M/L			-	-	400	
	1S 0024M/L			-	-	400	
	1S 0048M/L			-	-	400	
	1D 2424M (V1) 1D 2424M (V2)			-	-	200 200	
Capacitance for Dynamic Loading	1S 0005M/L	Start up	C_O	-	-	820	μF
	1S 0012M/L			-	-	470	
	1S 0015M/L			-	-	220	
	1S 0024M/L			-	-	220	
	1S 0048M/L			-	-	220	
	1D 2424M (V1) 1D 2424M (V2)			-	-	100 100	
Standby Output	Voltage Current	All	V_{SB} I_{SB}	- -	5 -	- 2	Vdc A
Power Density		$I_O = 100\%I_{O,max}$		-	18.18	-	W/in ³
Output Operating Modes		Single Output Modules		DVS - Digital Voltage Source DCS - Digital Current Source AVS - Analog Voltage Source ACS - Analog Current Source			
Max Number of Parallel Modules ¹		All		-	-	8	Modules
Max String Voltage for Series Configuration ¹		All		-	-	60	Vdc
V_O Current Share Accuracy		$I_O = 50\%$ to $100\%I_{O,max}$	$\%I_O$	-5	-	5	%
Remote Sense		Maximum compensation at each output line	$\%V_{nom}$	-	-	2	%
Isolated DCDC Converter Switching Frequency		Open Loop Resonant Converter	$f_{sw,DC}$	-	340	-	kHz
Output Adjustment/Programming Methods	Analog			0-5V programming 0-10V programming Fine tuning via trimpot			
	Digital			RS485 MODBUS RTU			

Note 1 - Inter-case configuration is not supported.

SECTION 2 ELECTRICAL SPECIFICATIONS

2.4 Output Specifications - Voltage Source (VS) Mode

Table 4. Output Specifications - Voltage Source (VS) Mode							
Parameter		Condition	Symbol	Min	Typ	Max	Unit
Factory Set Voltage	1S 0005M	$I_O = 0A$	$V_{O,Factory}$	-	5	-	Vdc
	1S 0012M			-	12	-	
	1S 0015M			-	15	-	
	1S 0024M			-	24	-	
	1S 0048M			-	48	-	
	1D 2424M (V1) 1D 2424M (V2)			-	24	-	
Output Voltage Adjust Range	1S 0005M	$I_O = 0A$	V_O	1.0	-	6.0	Vdc
	1S 0012M			2.4	-	14.4	
	1S 0015M			3.0	-	18.0	
	1S 0024M			4.8	-	28.8	
	1S 0048M			9.6	-	57.6	
	1D 2424M (V1) 1D 2424M (V2)			2.4	-	28.8	
Output Current ¹	1S 0005M	$V_O \leq 100\%V_{nom}$	I_O	0	-	56.0	A
	1S 0012M	$V_O \leq 80\%V_{nom}$		0	-	41.6	
	1S 0015M			0	-	33.3	
	1S 0024M			0	-	20.8	
	1S 0048M			0	-	10.4	
	1D 2424M (V1) 1D 2424M (V2)			0	-	10.4	
Turn-on Overshoot	1S 0005M		$I_O = 0A$	$\%V_O^2$	-	-	7.5
	1S 0012M	-			-	5.0	
	1S 0015M	-			-	5.0	
	1S 0024M	-			-	5.0	
	1S 0048M	-			-	5.0	
Turn-off Undershoot	1S 0005M	$I_O = 0A$	$\%V_O^2$	-7.5	-	-	%
	1S 0012M			-5.0	-	-	
	1S 0015M			-5.0	-	-	
	1S 0024M			-5.0	-	-	
	1S 0048M			-5.0	-	-	

Note 1 - Allowed output current at output voltage equal to 80% of V_{nom} .

Note 2 - V_{set} or V_{nom} , whichever is greater.

SECTION 2 ELECTRICAL SPECIFICATIONS

2.4 Output Specifications - Voltage Source (VS) Mode

Table 4. Output Specifications - Voltage Source (VS) Mode con't

Parameter	Condition	Symbol	Min	Typ	Max	Unit	
Dynamic Response Voltage Deviation	1S 0005M	Start from 20% of Irated 50% load change Slew rate = 1A/μs	%V _O ²	-7.5	-	7.5	%
	1S 0012M			-5.0	-	5.0	
	1S 0015M			-5.0	-	5.0	
	1S 0024M			-5.0	-	5.0	
	1S 0048M			-5.0	-	5.0	
Line Regulation	All	%V _{nom}	-1	-	1	%	
Load Regulation	All	%V _{nom}	-1	-	1	%	
Ripple & Noise - Peak to Peak	20MHz bandwidth	%V _O ³	-	-	1.0	%	
Ripple & Noise - RMS	20MHz bandwidth	%V _O ⁴	-	-	0.1	%	
Ripple & Noise - Common Mode	20MHz bandwidth	%V _O ⁵	-	-	0.1	%	
Programming Accuracy	Via digital command Via analog signal	%V _O ⁶	-1 -1.5	- -	1 1.5	%	
Monitoring Accuracy	Via digital command Via analog signal	%V _O ⁷	-1 -1.5	- -	1 1.5	%	

Note 3 - Vset or Vnom, whichever is greater. Measured with a 0.1μF ceramic capacitor in parallel with a 10μF tantalum or low ESR E-cap.

Note 4 - Vset or Vnom or 10mV, whichever is greater. Measured with a 0.1μF ceramic capacitor in parallel with a 10μF tantalum or low ESR E-cap.

Note 5 - Applicable for low noise variants only.

Vset or Vnom or 10mVpp, whichever is greater. Measured with a 0.1μF ceramic capacitor in parallel with a 10μF tantalum or low ESR E-cap.

Note 6 - Vset or Vnom, whichever is greater.

Note 7 - ±(1% of Vset + 1% of Vnom), or ±(1.5% of Vset + 1.5% of Vnom)

SECTION 2 ELECTRICAL SPECIFICATIONS

2.5 Output Specifications - Current Source (CS) Mode

Table 5. Output Specifications - Current Source (CS) Mode							
Parameter		Condition	Symbol	Min	Typ	Max	Unit
Minimum Output Voltage	1S 0005M	$I_O = 0A$	V_O	1.0	-	-	Vdc
	1S 0012M			2.4	-	-	
	1S 0015M			3.0	-	-	
	1S 0024M			4.8	-	-	
	1S 0048M			9.6	-	-	
	1D 2424M (V1) 1D 2424M (V2)			2.4 2.4	- -	- -	
Output Current Adjust Range	1S 0005M	$V_O \leq 100\%V_{nom}$	I_O	2.8	-	56	A
	1S 0012M	$V_O \leq 80\%V_{nom}$	I_O	1.66	-	41.6	
	1S 0015M			1.33	-	33.3	
	1S 0024M			0.83	-	20.8	
	1S 0048M			0.42	-	10.4	
	1D 2424M (V1) 1D 2424M (V2)			0.3 0.3	- -	10.4 10.4	
Rated Output Current	1S 0005M			$V_O = V_{nom}$	I_O	-	56
	1S 0012M	-	33.3			-	
	1S 0015M	-	26.6			-	
	1S 0024M	-	16.6			-	
	1S 0048M	-	8.3			-	
	1D 2424M (V1) 1D 2424M (V2)	- -	8.35 8.35			- -	
Line Regulation		All	$\%I_{rated}$	-1	-	1	%
Load Regulation		All	$\%I_{rated}$	-1	-	1	%
Ripple & Noise - RMS		20MHz bandwidth	$\%I_O^1$	-	-	1	%
Turn-on Overshoot		All	$\%I_O^2$	-	-	5	%
Turn-off Undershoot		All	$\%I_O^2$	-5	-	-	%
Programming Accuracy		Via digital command Via analog signal	$\%I_O^2$	-1	-	1	%
				-2	-	2	
Monitoring Accuracy		Via digital command Via analog signal	$\%I_O^3$	-1	-	1	%
				-2	-	2	

Note 1 - Iset or Irated, whichever is greater. Measured using oscilloscope current probe.

Note 2 - Iset or Irated, whichever is greater.

Note 3 - $\pm(1\%$ of Iset + 1% of Irated), or $\pm(2\%$ of Iset + 2% of Irated)

SECTION 2 ELECTRICAL SPECIFICATIONS

2.6 System Timing Specifications

Table 6. System Timing Specifications					
Label	Parameter	Min	Typ	Max	Unit
T1	Delay from AC being applied to V_{SB} being within regulation	-	2	-	s
T2	Delay from V_{SB} to main output voltage V_O being within regulation	-	10	-	s
T3	Delay from AC being applied to ACOK assertion	-	400	-	ms
T4	Delay from AC being applied to output voltages being within regulation with Global Inhibit asserted low	-	12	-	s
T5	Rise time, from 10% V_O to 90% V_O (adjustable)	20	-	100	ms
T6	Delay from output voltages within regulation limits to Global PGOOD asserted	-	300	-	ms
T7	Delay from loss of AC input to ACOK going to de-assertion	-	50	-	ms
T8	Hold up time - Delay from loss of AC to main output remain within regulation	20	-	-	ms
T9	Delay from loss of AC to de-assertion of Global PGOOD	-	50	-	ms
T10	Delay from output voltages dropping out of regulation limits to Global PGOOD de-assertion	-	10	-	ms
T11	Delay from Global Inhibit active to output voltages within regulation limits	-	240	-	ms

SECTION 2 ELECTRICAL SPECIFICATIONS

2.7 System Timing Diagram

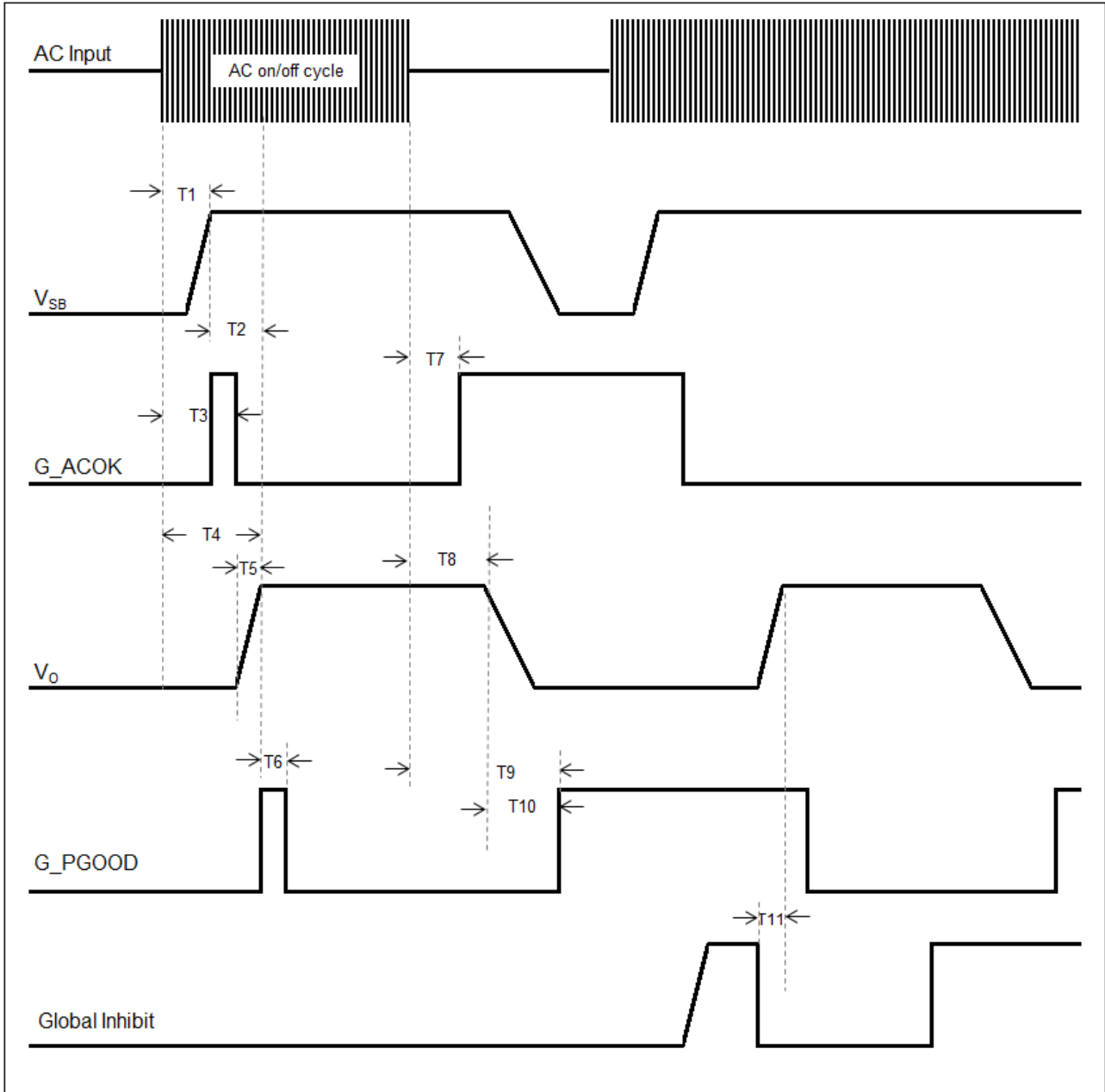

SECTION 2 ELECTRICAL SPECIFICATIONS

2.8 NP08 Case Performance Curves



Figure 1: NP08W1-1MW0(8)-00-18P-A-0 Turn-on delay via AC mains
 Vin = 90Vac Load: $I_o = 41.67A$ $I_{SB} = 1A$
 Ch 1: AC Mains Ch 2: V_{SB} Ch 3: V_o Ch 4: G_PG00D

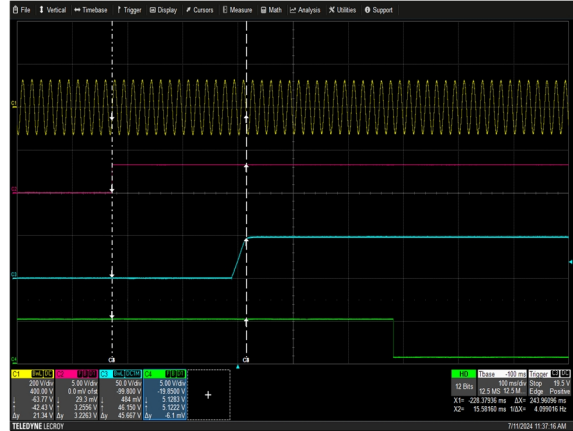

Figure 2: NP08W1-1MW0(8)-00-18P-A-0 Turn-on delay via Global Inhibit
 Vin = 90Vac Load: $I_o = 41.67A$ $I_{SB} = 1A$
 Ch 1: AC Mains Ch 2: INH0 Ch 3: V_o Ch 4: G_PG00D



Figure 3: NP08W1-1MW0(8)-00-18P-A-0 Turn-on delay via AC mains
 Vin = 264Vac Load: $I_o = 66.67A$ $I_{SB} = 1A$
 Ch 1: AC Mains Ch 2: V_{SB} Ch 3: V_o Ch 4: G_PG00D

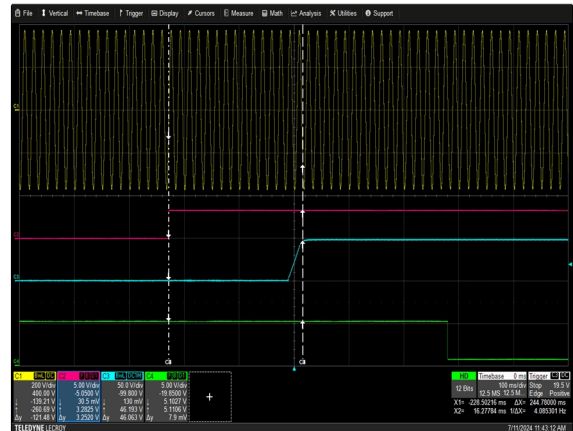

Figure 4: NP08W1-1MW0(8)-00-18P-A-0 Turn-on delay via Global Inhibit
 Vin = 264Vac Load: $I_o = 66.67A$ $I_{SB} = 1A$
 Ch 1: AC Mains Ch 2: INH0 Ch 3: V_o Ch 4: G_PG00D



Figure 5: NP08W1-1MW0(8)-00-18P-A-0 Hold-up Time
 Vin = 90Vac/63Hz/0° Load: $I_o = 41.67A$ $I_{SB} = 1A$
 Ch 1: AC Mains Ch 2: V_{SB} Ch 3: V_o Ch 4: G_PG00D

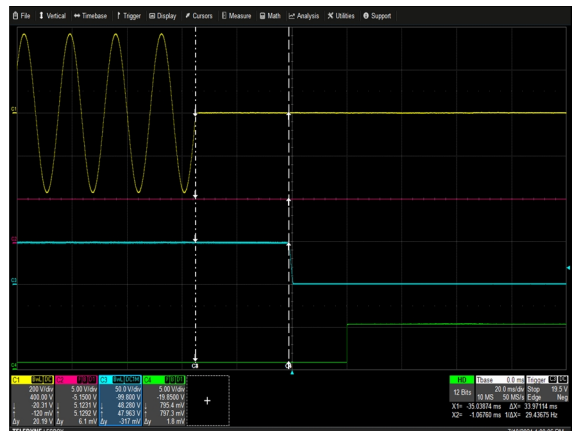

Figure 6: NP08W1-1MW0(8)-00-18P-A-0 Hold-up Time
 Vin = 264Vac/47Hz/0° Load: $I_o = 66.67A$ $I_{SB} = 1A$
 Ch 1: AC Mains Ch 2: V_{SB} Ch 3: V_o Ch 4: G_PG00D

SECTION 2 ELECTRICAL SPECIFICATIONS

2.8 NP08 Case Performance Curves

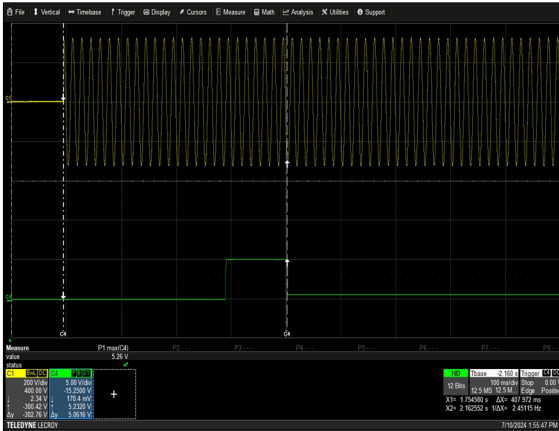

Figure 7: NP08W1-1MW0-00-A-0 ACOK Assert Characteristic
 Vin = 230Vac Load: Io = 8.3A
 Ch 1: AC Mains Ch 4: G_ACOK

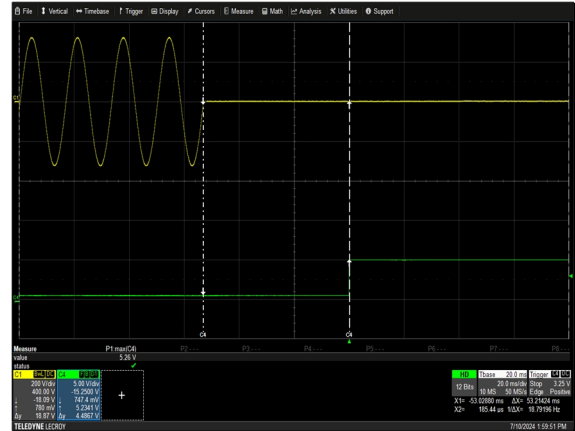

Figure 8: NP08W1-1MW0-00-A-0 ACOK De-assert Characteristic
 Vin = 230Vac Load: Io = 8.3A
 Ch 1: AC Mains Ch 4: G_ACOK

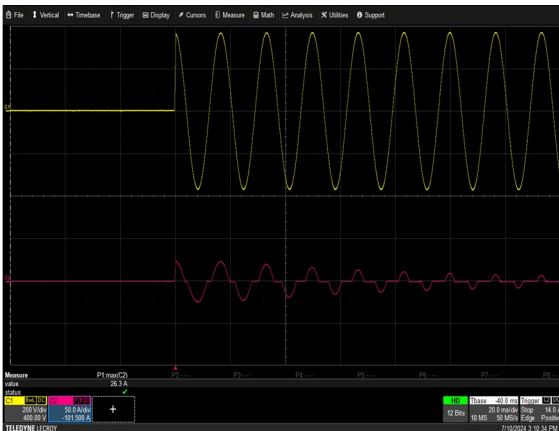

Figure 9: NP08W1-1MW0-00-A-0 Start up Inrush Current
 Vin = 264Vac Load: Io = 0A Turn On Phase = 90°
 Ch 1: VIN Ch 2: IIN

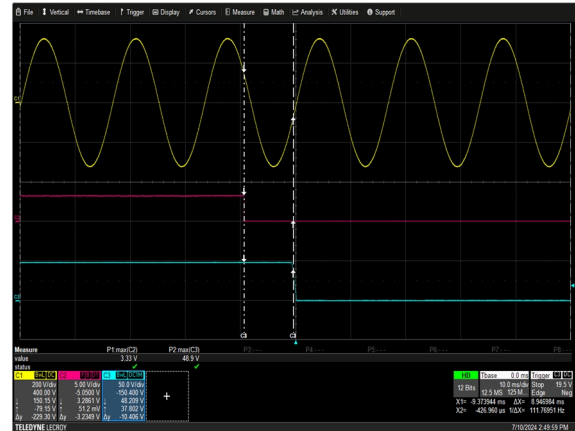

Figure 10: NP08W1-1MW0-00-A-0 Turn Off via Global Inhibit
 Vin = 230Vac Load: Io = 8.3A
 Ch 1: AC Mains Ch 2: INH0 Ch 3: VO

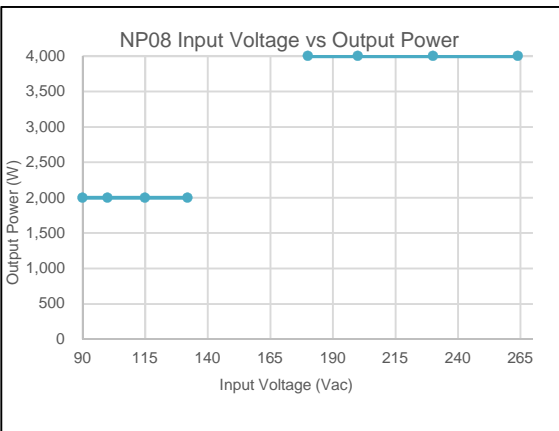

Figure 11: NP08 Input Voltage vs Output Power
 Loading: Io,max = Io,max

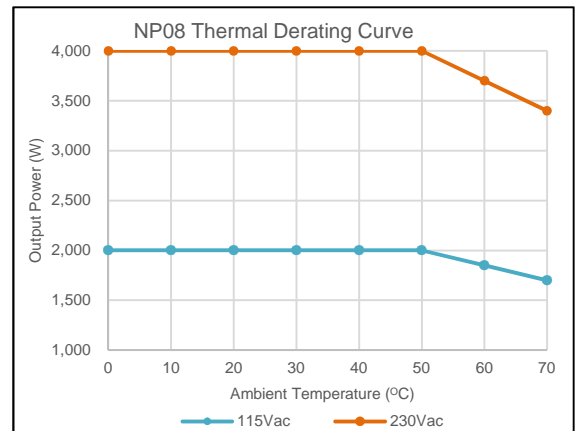

Figure 12: NP08 Thermal Derating Curves at Sea Level
 Vin = 115 & 230Vac

SECTION 2 ELECTRICAL SPECIFICATIONS

2.8 NP08 Case Performance Curves

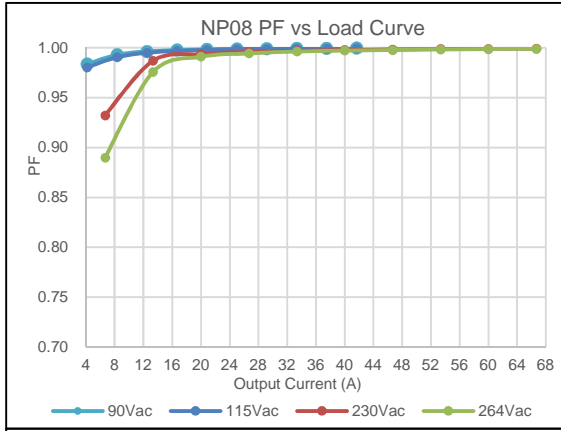

Figure 13: NP08W1-1MW0(8)-00-18P-A-0 PF vs Load Curve

Loading: $I_{o,max} = I_{o,max}$

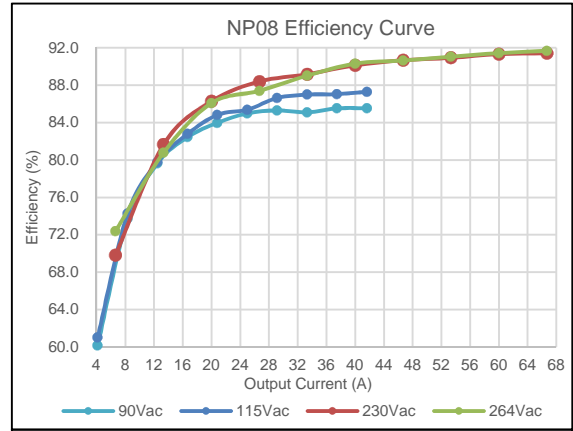

Figure 14: NP08W1-1MW0(8)-00-18P-A-0 Efficiency Curve @ 25°C

Loading: $I_{o,max} = 10\%I_{o,max}$ increment to $I_{o,max}$

SECTION 2 ELECTRICAL SPECIFICATIONS

2.9 5V 280W Module (1S 0005M) Performance Curves - Voltage Mode

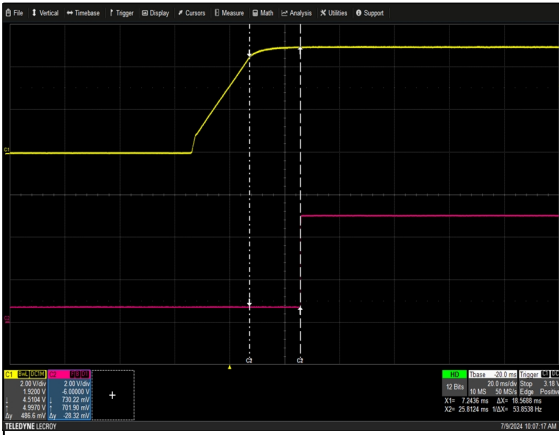

Figure 15: NP08W1-1ME0-00-A-0 Output Voltage Startup Characteristic
Load: $I_o = 56A$
Ch 1: V_o Ch 2: ISO_POWER_GOOD

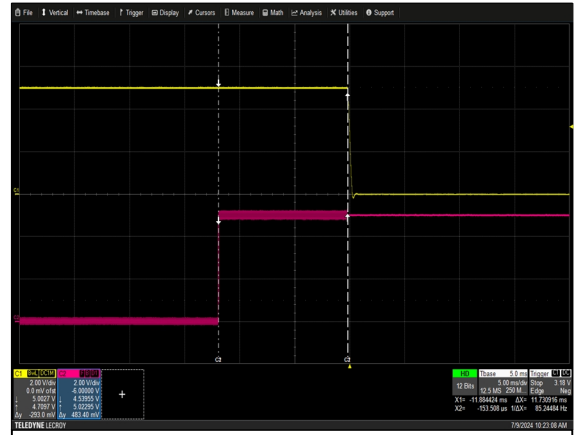

Figure 16: NP08W1-1ME0-00-A-0 Turn Off via Module Inhibit
Load: $I_o = 56A$
Ch 1: V_o Ch 2: Module Inhibit

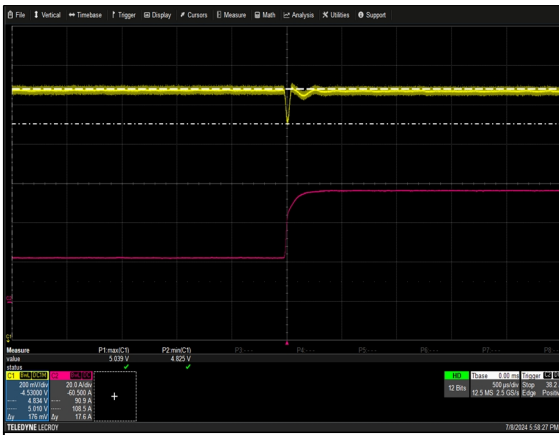

Figure 17: NP08W1-1ME0-00-A-0 Transient Response - V_o Deviation
40% to 100% load change, 1A/ μs slew rate
Ch 1: V_o Ch 2: I_o



Figure 18: NP08W1-1ME0-00-A-0 Transient Response - V_o Deviation
100% to 40% load change, 1A/ μs slew rate
Ch 1: V_o Ch 2: I_o

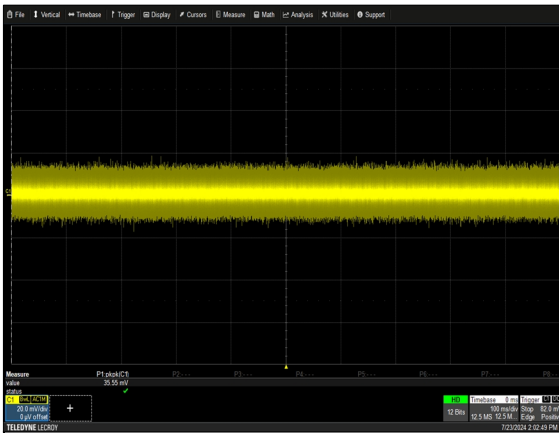

Figure 19: NP08W1-1ME0-00-A-0 Ripple and Noise Measurement
Load: $I_o = 56A$
Ch 1: V_o

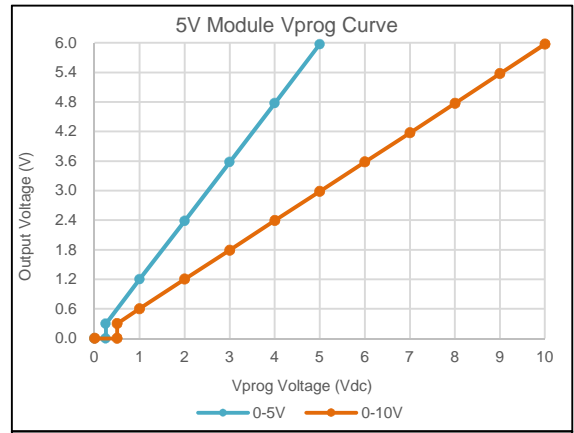

Figure 20: NP08W1-1ME0-00-A-0 Output Voltage Adjustment @ 25°C
 $I_o = 0A$

SECTION 2 ELECTRICAL SPECIFICATIONS

2.9 5V 280W Module (1S 0005M) Performance Curves - Current Mode

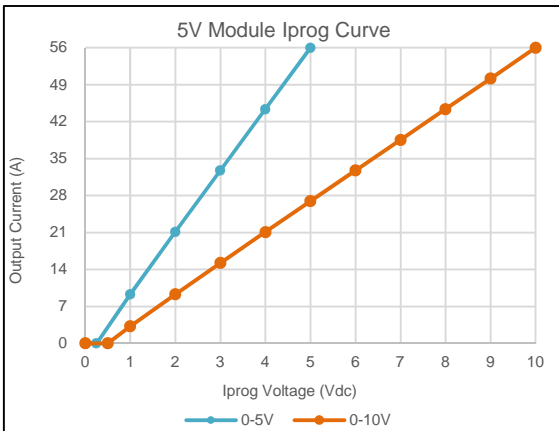
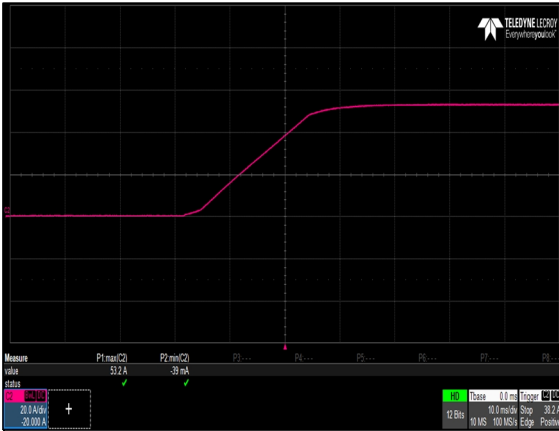

Figure 23: NP08W1-1ME0-00-A-0 Output Current Adjustment @ 25°C
Load: R = 0.05 ohm

SECTION 2 ELECTRICAL SPECIFICATIONS

2.9 12V 400W Module (1S 0012M) Performance Curves - Voltage Mode

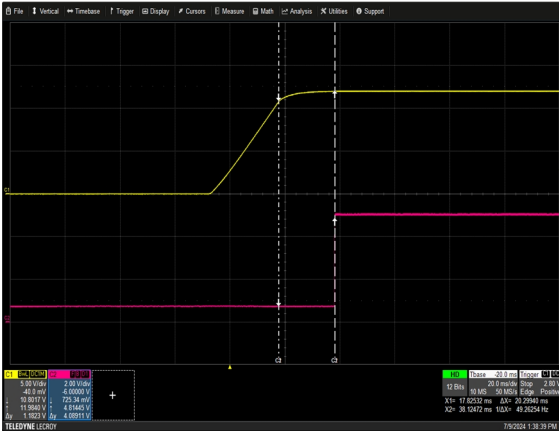

Figure 24: NP08W1-1ML0-00-A-0 Output Voltage Startup Characteristic
Load: $I_o = 33.3A$
Ch 1: V_O Ch 2: ISO_POWER_GOOD



Figure 25: NP08W1-1ML0-00-A-0 Turn Off via Module Inhibit
Load: $I_o = 33.3A$
Ch 1: V_O Ch 2: Module Inhibit

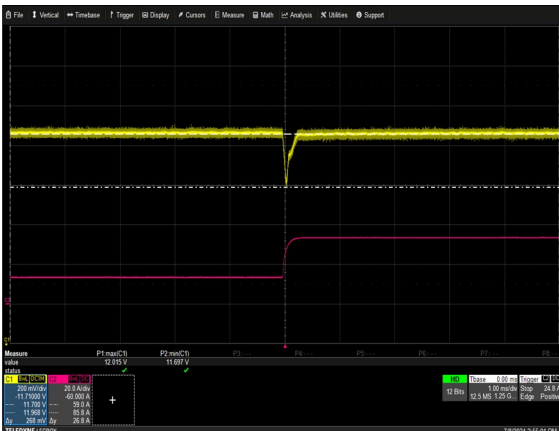

Figure 26: NP08W1-1ML0-00-A-0 Transient Response - V_O Deviation
40% to 100% load change, 1A/ μS slew rate
Ch 1: V_O Ch 2: I_o

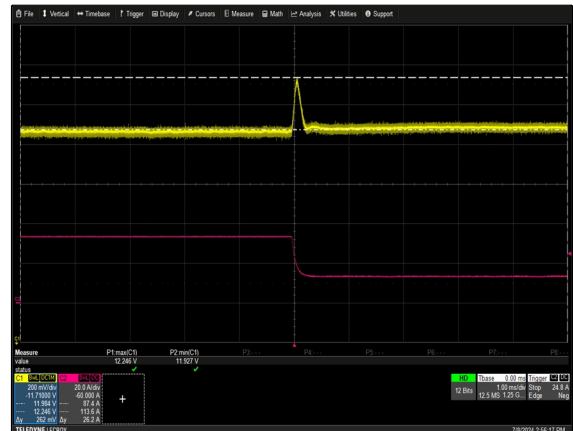

Figure 27: NP08W1-1ML0-00-A-0 Transient Response - V_O Deviation
100% to 40% load change, 1A/ μS slew rate
Ch 1: V_O Ch 2: I_o

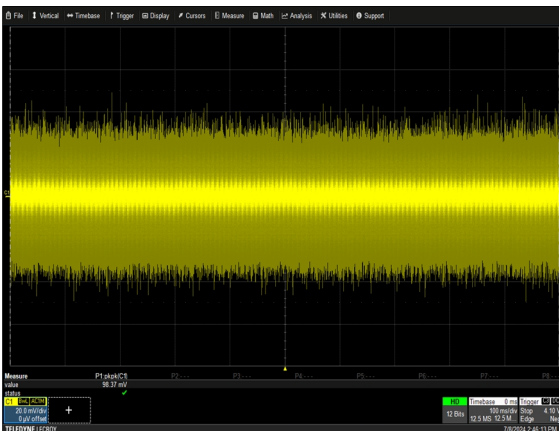

Figure 28: NP08W1-1ML0-00-A-0 Ripple and Noise Measurement
Load: $I_o = 33.3A$
Ch 1: V_O

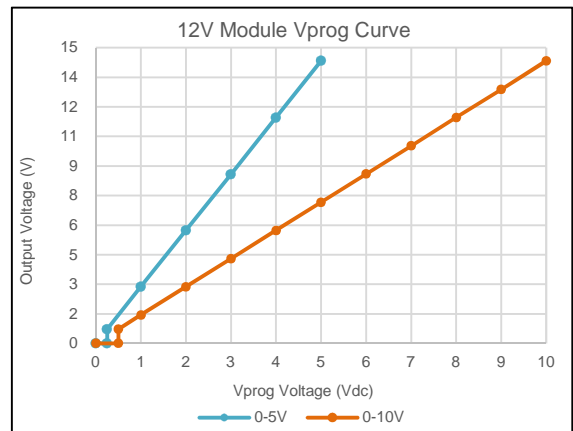

Figure 29: NP08W1-1ML0-00-A-0 Output Voltage Adjustment @ 25°C
 $I_o = 0A$

SECTION 2 ELECTRICAL SPECIFICATIONS

2.9 12V 400W Module (1S 0012M) Performance Curves - Current Mode



Figure 30: NP08W1-1ML0-00-A-0 Output Current Startup Characteristic
Load: R = 0.36 ohm
Ch 2: I_O

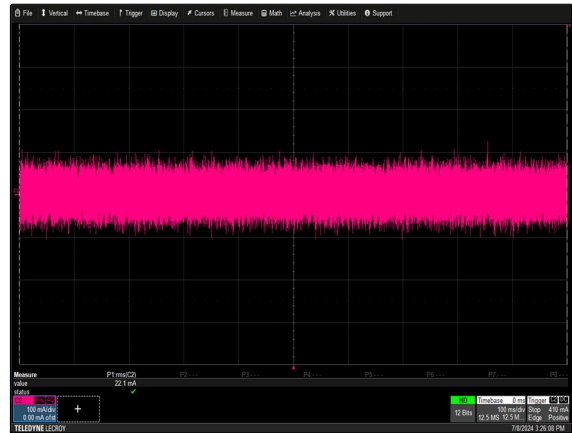

Figure 31: NP08W1-1ML0-00-A-0 Ripple and Noise Measurement
Load: R = 0.36 ohm
Ch 2: I_O

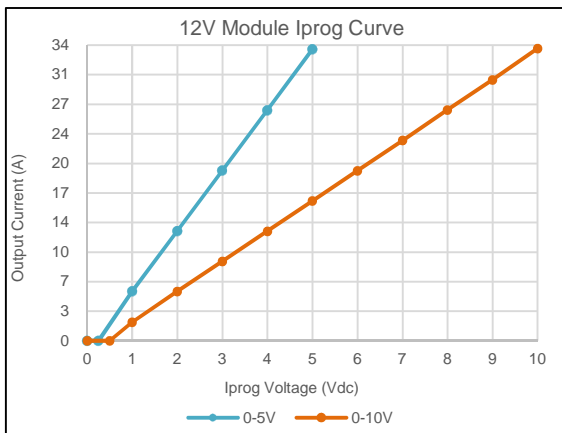

Figure 32: NP08W1-1ML0-00-A-0 Output Current Adjustment @ 25°C
Load: R = 0.3 ohm

SECTION 2 ELECTRICAL SPECIFICATIONS

2.9 15V 400W Module (1S 0015M) Performance Curves - Voltage Mode



Figure 33: NP08W1-1MN0-00-A-0 Output Voltage Startup Characteristic
Load: $I_o = 26.6A$
Ch 1: V_o Ch 2: ISO_POWER_GOOD



Figure 34: NP08W1-1MN0-00-A-0 Turn Off via Module Inhibit
Load: $I_o = 26.6A$
Ch 1: V_o Ch 2: Module Inhibit



Figure 35: NP08W1-1MN0-00-A-0 Transient Response - V_o Deviation
40% to 100% load change, 1A/ μs slew rate
Ch 1: V_o Ch 2: I_o



Figure 36: NP08W1-1MN0-00-A-0 Transient Response - V_o Deviation
100% to 40% load change, 1A/ μs slew rate
Ch 1: V_o Ch 2: I_o

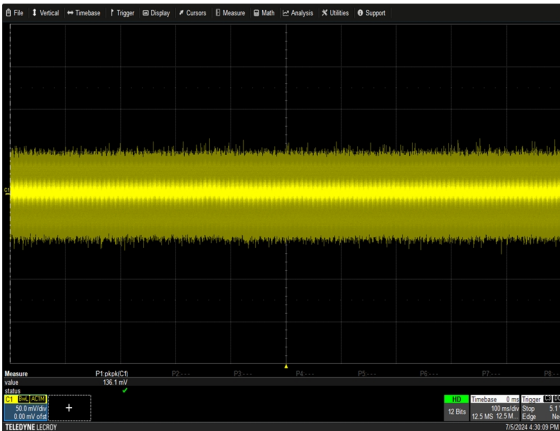

Figure 37: NP08W1-1MN0-00-A-0 Ripple and Noise Measurement
Load: $I_o = 26.6A$
Ch 1: V_o

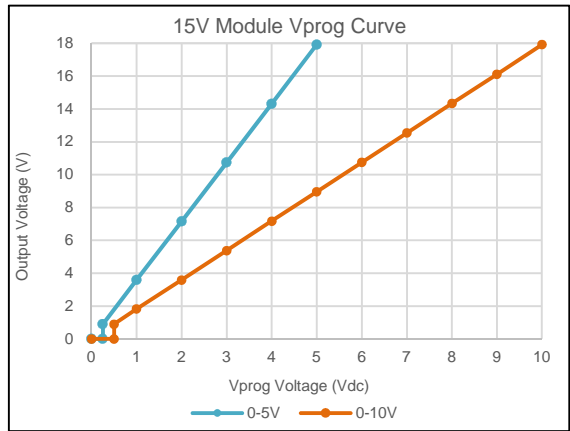

Figure 38: NP08W1-1MN0-00-A-0 Output Voltage Adjustment @ 25°C
 $I_o = 0A$

SECTION 2 ELECTRICAL SPECIFICATIONS

2.9 15V 400W Module (1S 0015M) Performance Curves - Current Mode



Figure 39: NP08W1-1MN0-00-A-0 Output Current Startup Characteristic
Load: R = 0.55 ohm
Ch 2: I_o



Figure 40: NP08W1-1MN0-00-A-0 Ripple and Noise Measurement
Load: R = 0.55 ohm
Ch 2: I_o

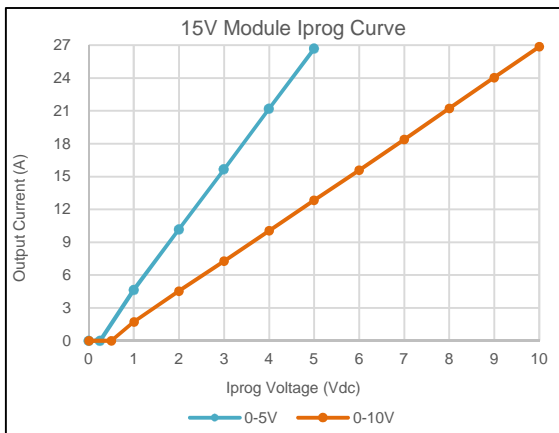

Figure 41: NP08W1-1MN0-00-A-0 Output Current Adjustment @ 25°C
Load: R = 0.5 ohm

SECTION 2 ELECTRICAL SPECIFICATIONS

2.9 24V 400W Module (1S 0024M) Performance Curves - Voltage Mode



Figure 42: NP08W1-1MQ0-00-A-0 Output Voltage Startup Characteristic
Load: $I_o = 16.6A$
Ch 1: V_O Ch 2: ISO_POWER_GOOD



Figure 43: NP08W1-1MQ0-00-A-0 Turn Off via Module Inhibit
Load: $I_o = 16.6A$
Ch 1: V_O Ch 2: Module Inhibit

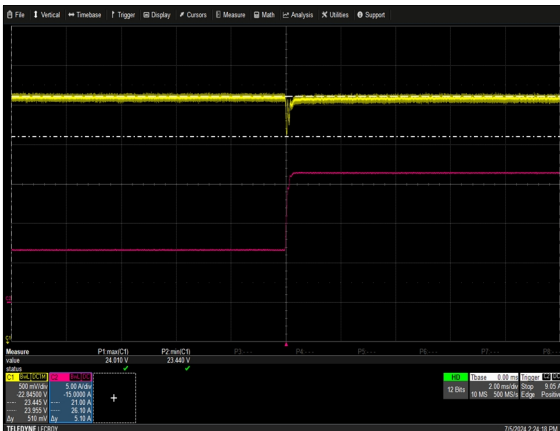

Figure 44: NP08W1-1MQ0-00-A-0 Transient Response - V_O Deviation
40% to 100% load change, $1A/\mu S$ slew rate
Ch 1: V_O Ch 2: I_O

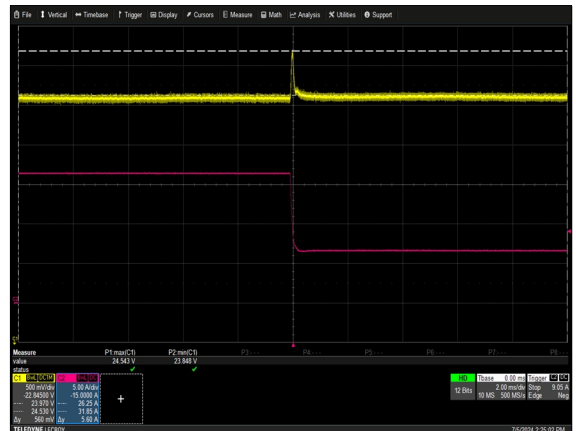

Figure 45: NP08W1-1MQ0-00-A-0 Transient Response - V_O Deviation
100% to 40% load change, $1A/\mu S$ slew rate
Ch 1: V_O Ch 2: I_O

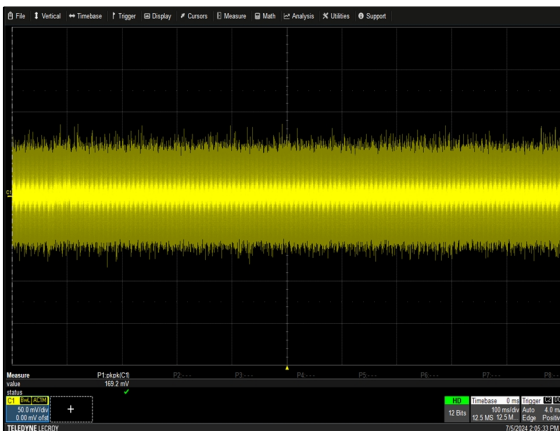

Figure 46: NP08W1-1MQ0-00-A-0 Ripple and Noise Measurement
Load: $I_o = 16.6A$
Ch 1: V_O

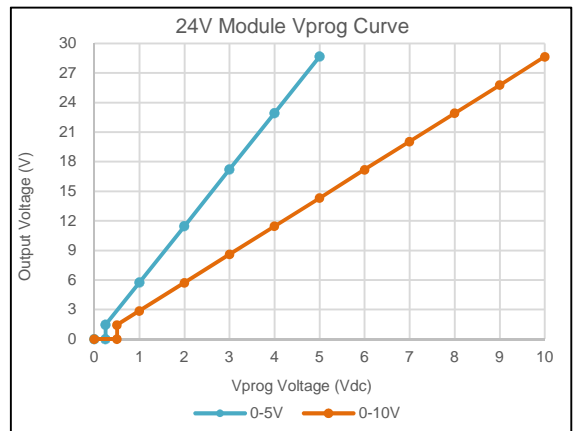

Figure 47: NP08W1-1MQ0-00-A-0 Output Voltage Adjustment @ 25°C
 $I_o = 0A$

SECTION 2 ELECTRICAL SPECIFICATIONS

2.9 24V 400W Module (1S 0024M) Performance Curves - Current Mode



Figure 48: NP08W1-1MQ0-00-A-0 Output Current Startup Characteristic
Load: R = 1.43 ohm
Ch 2: I_O



Figure 49: NP08W1-1MQ0-00-A-0 Ripple and Noise Measurement
Load: R = 1.43 ohm
Ch 2: I_O

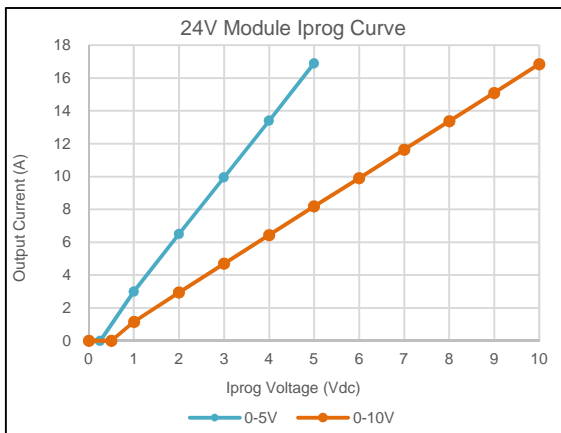

Figure 50: NP08W1-1MQ0-00-A-0 Output Current Adjustment @ 25°C
Load: R = 1.3 ohm

SECTION 2 ELECTRICAL SPECIFICATIONS

2.9 48V 400W Module (1S 0048M) Performance Curves - Voltage Mode



Figure 51: NP08W1-1MW0-00-A-0 Output Voltage Startup Characteristic
Load: $I_o = 8.3A$
Ch 1: V_o Ch 2: ISO_POWER_GOOD



Figure 52: NP08W1-1MW0-00-A-0 Turn Off via Module Inhibit
Load: $I_o = 8.3A$
Ch 1: V_o Ch 2: Module Inhibit

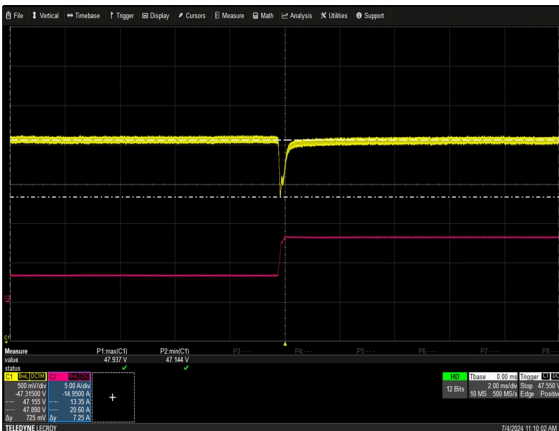

Figure 53: NP08W1-1MW0-00-A-0 Transient Response - V_o Deviation
40% to 100% load change, $1A/\mu s$ slew rate
Ch 1: V_o Ch 2: I_o

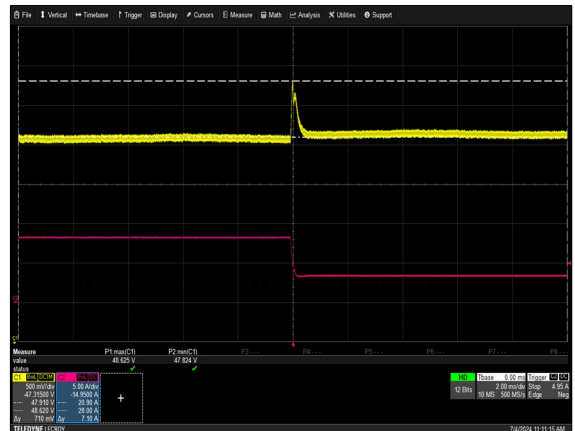

Figure 54: NP08W1-1MW0-00-A-0 Transient Response - V_o Deviation
100% to 40% load change, $1A/\mu s$ slew rate
Ch 1: V_o Ch 2: I_o

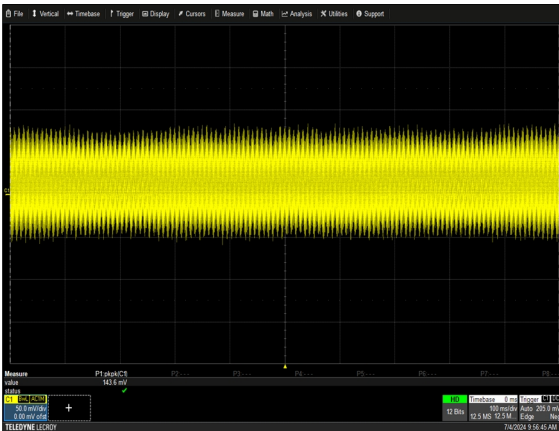

Figure 55: NP08W1-1MW0-00-A-0 Ripple and Noise Measurement
Load: $I_o = 8.3A$
Ch 1: V_o

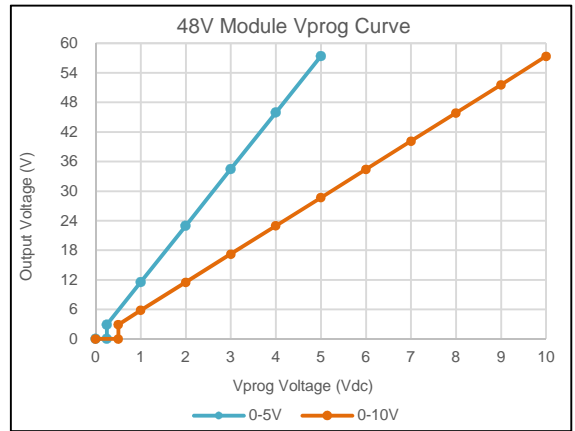

Figure 56: NP08W1-1MW0-00-A-0 Output Voltage Adjustment @ 25°C
 $I_o = 0A$

SECTION 2 ELECTRICAL SPECIFICATIONS

2.9 48V 400W Module (1S 0048M) Performance Curves - Current Mode

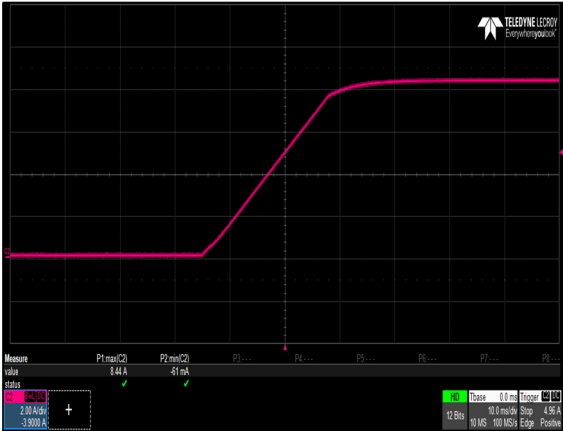

Figure 57: NP08W1-1MW0-00-A-0 Output Current Startup Characteristic
Load: R = 5.78 ohm
Ch 2: I_O



Figure 58: NP08W1-1MW0-00-A-0 Ripple and Noise Measurement
Load: R = 5.78 ohm
Ch 2: I_O

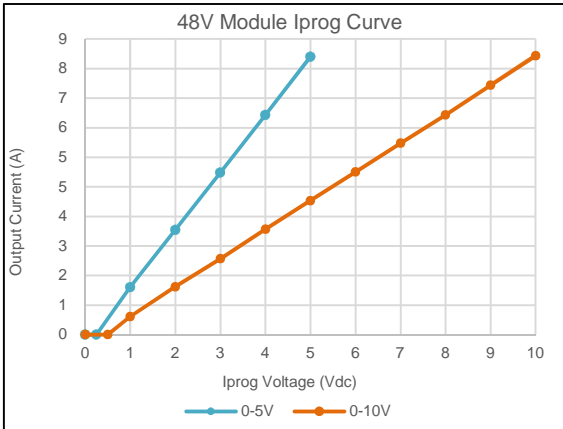

Figure 59: NP08W1-1MW0-00-A-0 Output Current Adjustment @ 25°C
Load: R = 5.5 ohm

SECTION 2 ELECTRICAL SPECIFICATIONS

2.10 Protection Function Specifications

Input Fuse

The NP08 Series is equipped with internal non user serviceable 40A 250Vac fast acting fuse for fault protection on both L line and N line input.

Input Over Voltage Protection

The NP08 series power supply withstands a continuous over input voltage up to 115% of nominal input voltage with no permanent damage.

Parameter	Min	Nom	Max	Unit
Input Overvoltage - Low Line	/	/	150	Vac
Input Overvoltage - High Line	/	/	275	Vac

Output Over Voltage Protection (OVP)

The NP08 series power supply latches off during output overvoltage with the AC line recycled or clear faults digital register to reset the latch.

Parameter	Min	Nom	Max	Unit
Output Overvoltage	110	/	120	%V _{set}

Output Under Voltage Protection (UVP)

The NP08 series power supply can detect an under voltage condition in which the output voltage does not achieve its set point voltage. The UVP is programmable from 80% to 90% of the target output voltage.

Parameter	Min	Nom	Max	Unit
Output Undervoltage	80	/	90	%V _{set}

Over Current Protection (OCP)

The main output is internally protected against output overload and/or over current events. No damage will result to the power supply as the result of either short term or long term overload.

The OCP mode can be selected as constant current or latch. In CC mode, the latch mode is disabled.

In latch mode, the CC limit is set to 3% above latch level, since latch model has around 100ms validation time before shutting down the module.

The OCP threshold is programmable from 10% to 105% of the maximum output current.

Parameter	Min	Nom	Max	Unit
Output Over Current	10	/	105	%I _{O,max}

SECTION 2 ELECTRICAL SPECIFICATIONS

Short Circuit Protection (SCP)

The NP08 series power supply withstands a continuous short circuit with no hard failure, safety hazards or reliability aftermath. permanent damage, applied to its main output during start-up or while running. Output will latch off.

Over Temperature Protection (OTP)

The NP08 series power supply is internally protected against over temperature conditions. When over temperature circuit is activated, the power supply output will shut-off, and auto-recover once the OTP condition is removed.

Constant Voltage Clamp

This feature is intended for Current Source (CS) mode operation.

During the operation of the CS mode, at the event where the load impedance increases, the resulting output voltage is clamped to a specified maximum level to avoid output overloading.

Once the desired clamp level is reached, the operation of the power supply automatically switches from Constant Current Mode to Constant Voltage Mode.

The constant voltage clamp threshold is programmable from 10% to 120% of Vnom.

Parameter	Min	Nom	Max	Unit
Constant Voltage Clamp	10	/	120	%V _{nom}

SECTION 3 MECHANICAL SPECIFICATIONS

3.1 NP05 Case Mechanical Outlines (unit: mm)

Typical Weight: 1500g

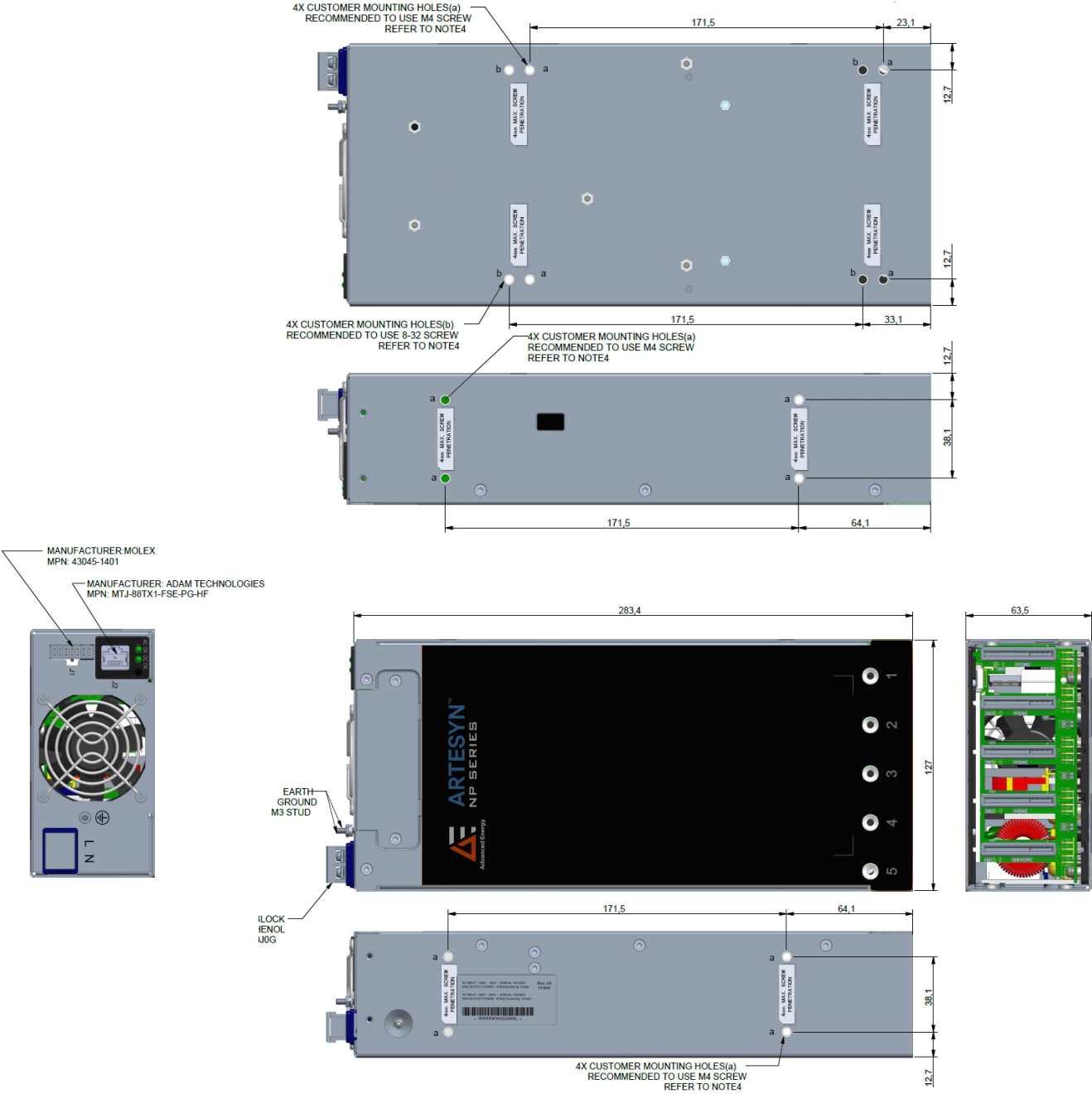

Note: Mounting – 3 sides M4, bottom also includes 8-32 mounting holes.
 Screw max. penetration is 0.155" (4.0mm)
 Screw max. torque: 5 in-lbs. (0.57N-m)

SECTION 3 MECHANICAL SPECIFICATIONS

3.2 NP08 Case Mechanical Outlines (unit: mm)

Typical Weight: 3200g

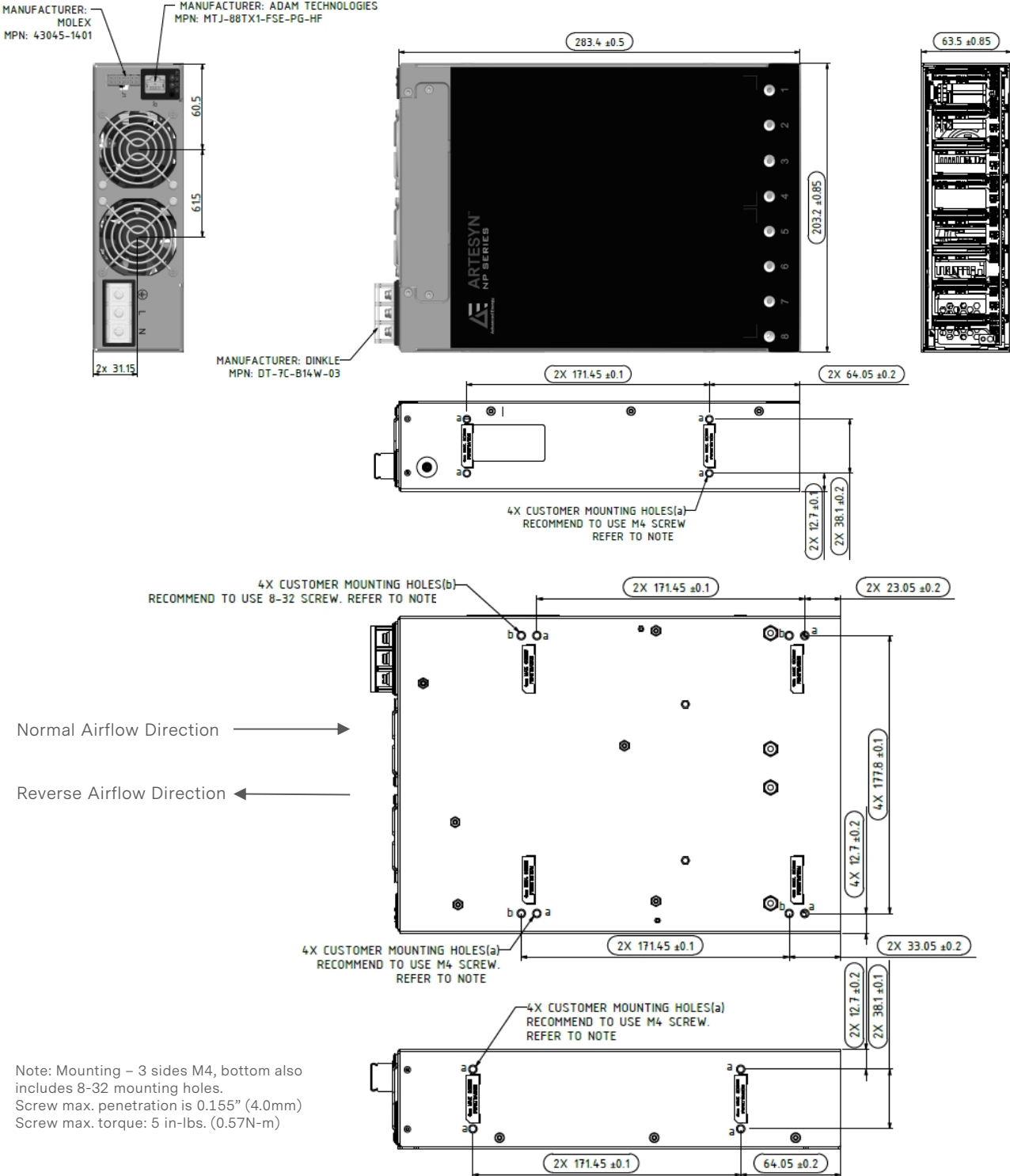

Note: Mounting – 3 sides M4, bottom also includes 8-32 mounting holes.
Screw max. penetration is 0.155" (4.0mm)
Screw max. torque: 5 in-lbs. (0.57N-m)

SECTION 3 MECHANICAL SPECIFICATIONS

3.3 1 Slot Single Output Medical Module Mechanical Outlines (unit: mm)

Typical Weight: 220g

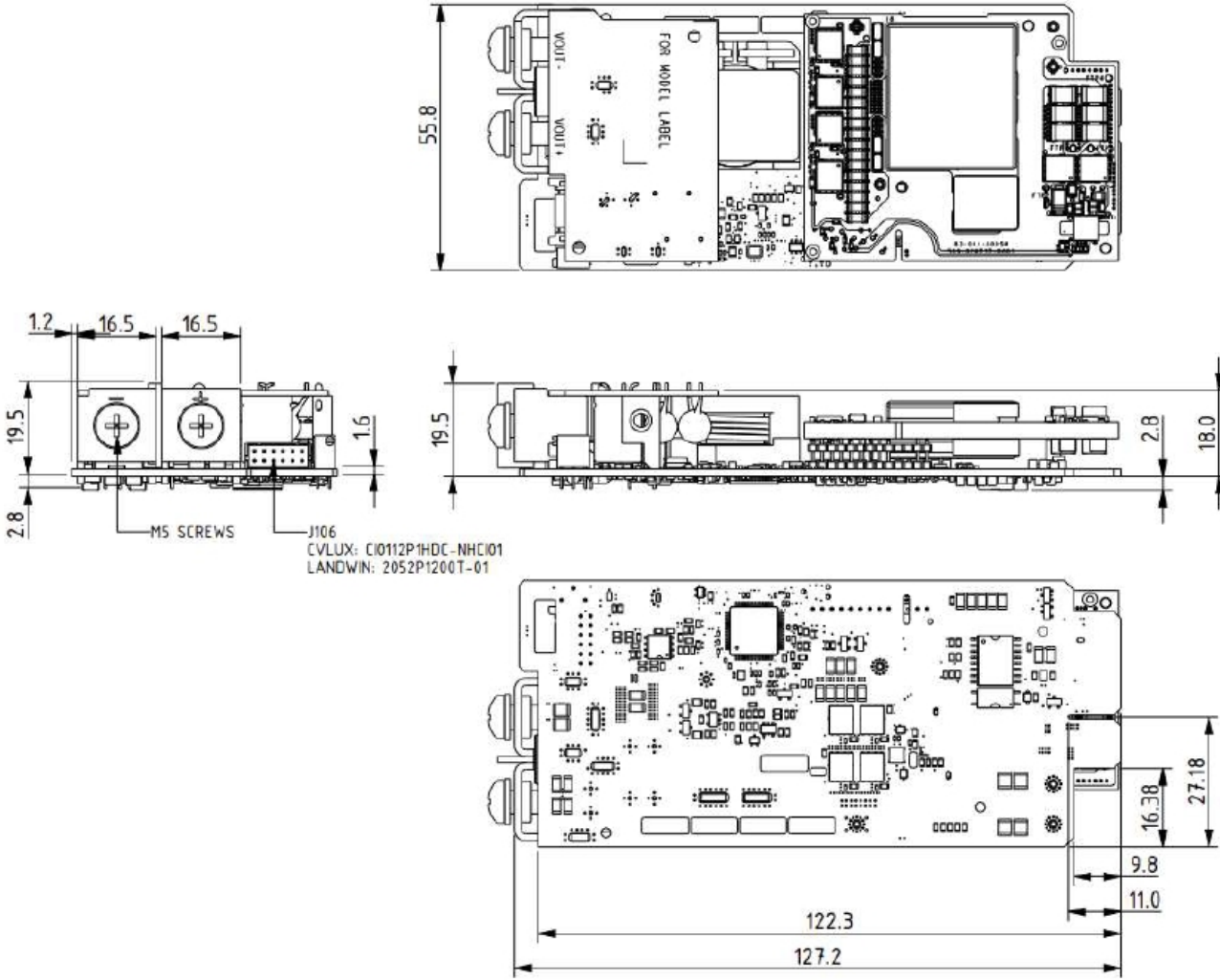

SECTION 3 MECHANICAL SPECIFICATIONS

3.4 1 Slot Single Output Low Noise Module Mechanical Outlines (unit: mm)

Typical Weight: 200g

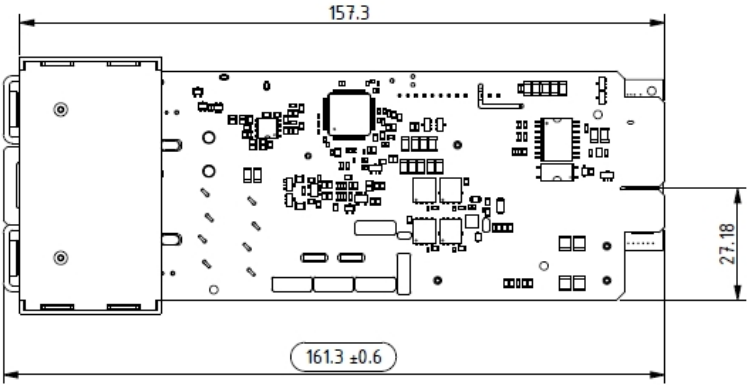
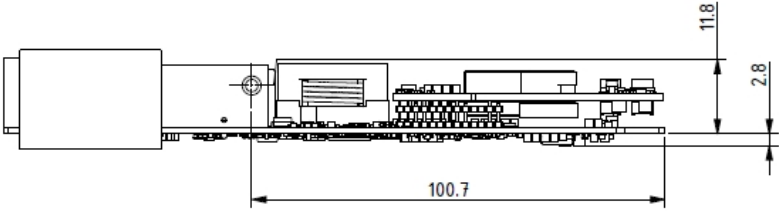
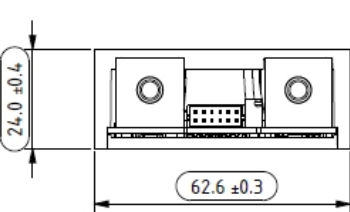
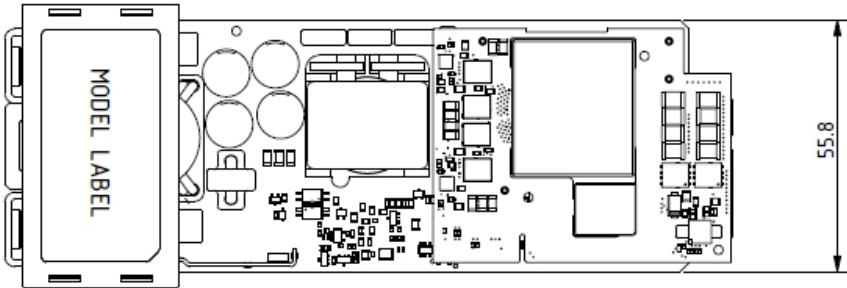

SECTION 3 MECHANICAL SPECIFICATIONS

3.5 1 Slot Dual Output Module Mechanical Outlines (unit: mm)

Typical Weight: 200g

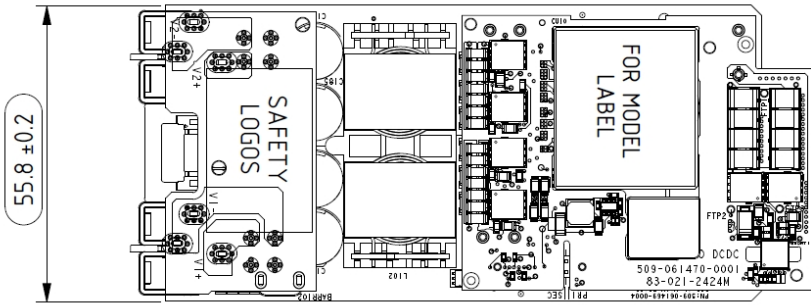

*NOTE: FOLLOW TEXT ORIENTATION ON LABEL PLACEMENT

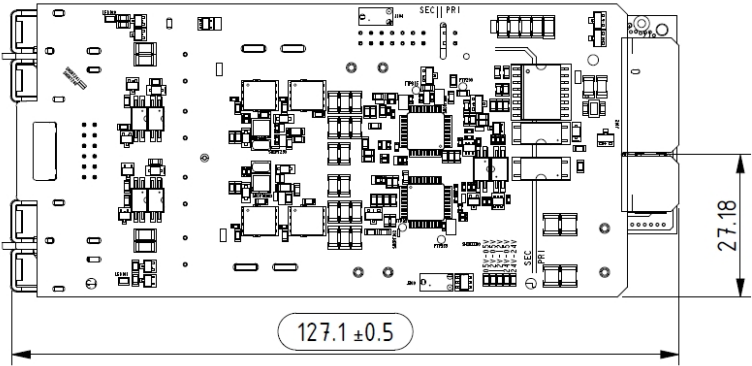
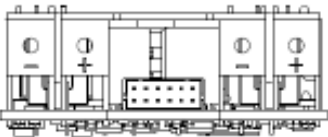
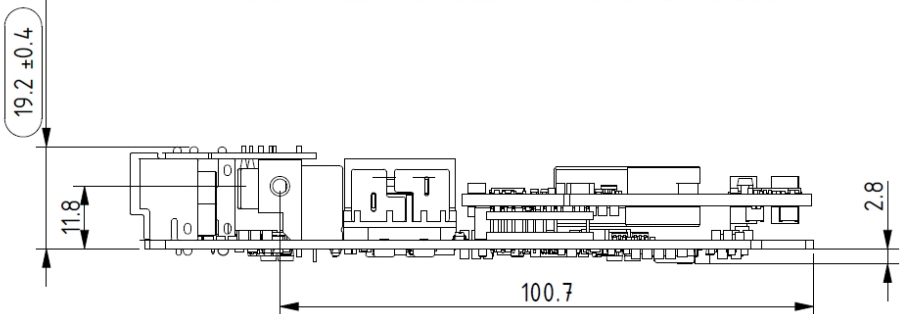

SECTION 3 MECHANICAL SPECIFICATIONS

3.6 Connector Definitions - Case

Input Terminal

- L - Line
- N - Neutral
-  - Ground

- ConnectedPower Bus Connector (J2)
- Signal Connector (J1)

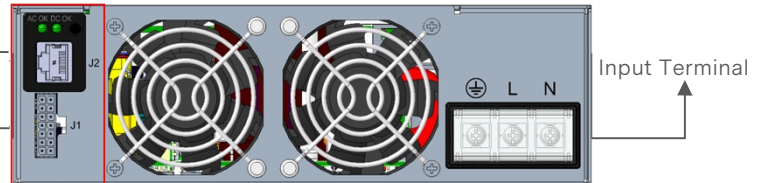

Signal Connector - J1

- Pin 1 - G_ACOK_E
- Pin 2 - G_PGOOD_E
- Pin 3 - INH0
- Pin 4 - ISO_RTN1
- Pin 5 - 5V_EXT
- Pin 6 - 5V_STBY
- Pin 7 - ISO_RTN1
- Pin 8 - G_ACOK_C
- Pin 9 - G_PGOOD_C
- Pin 10 - INH1
- Pin 11 - ISO_RTN1
- Pin 12 - ISO_RTN1
- Pin 13 - 5V_STBY_RTN
- Pin 14 - ISO_RTN1

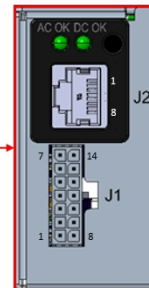

ConnectedPower Bus Connector - J2

- Pin 1 - RS485 A
- Pin 2 - RS485 B
- Pin 3 - ISO_RTN1
- Pin 4 - ISO_RTN1
- Pin 5 - ISO_RTN1
- Pin 6 - ISO_RTN1
- Pin 7 - +5V_Logic_Supply
- Pin 8 - +5V_Logic_Supply_Return

SECTION 3 MECHANICAL SPECIFICATIONS

3.7 Connector Definitions - Single Output Module

Main Output Terminals

- + - Positive Output
- - Negative Output

Signal Connector - J106

- Pin 1 - ISO_M_INHIBIT
- Pin 2 - ISO_M_INHIBIT_RTN
- Pin 3 - ISO_POWER_GOOD
- Pin 4 - ISO_POWER_GOOD_RTN
- Pin 5 - 0-10_VI_PROG
- Pin 6 - 0-5_VI_PROG
- Pin 7 - VI_TRIM_EN#
- Pin 8 - D_RTN
- Pin 9 - ISHARE
- Pin 10 - ISHARE_RTN
- Pin 11 - RS+
- Pin 12 - RS-

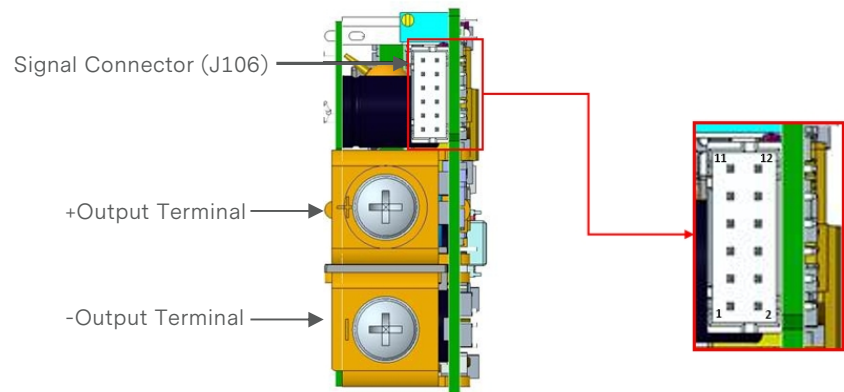

3.8 Connector Definitions - Dual Output Module

Main Output Terminals

- +V1 - Output 1 Positive Output
- V1 - Output 1 Negative Output
- +V2 - Output 2 Positive Output
- V2 - Output 2 Negative Output

Signal Connector - J106

- Pin 1 - RMT_SENSE+_2
- Pin 2 - RMT_SENSE-_2
- Pin 3 - ISO_POWER_GOOD_2
- Pin 4 - ISO_POWER_GOOD_RTN_2
- Pin 5 - ISO_M_INHIBIT_2
- Pin 6 - ISO_INHIBIT_RTN_2
- Pin 7 - ISO_POWER_GOOD_1
- Pin 8 - ISO_POWER_GOOD_RTN_1
- Pin 9 - ISO_M_INHIBIT_1
- Pin 10 - ISO_INHIBIT_RTN_1
- Pin 11 - RMT_SENSE+_1
- Pin 12 - RMT_SENSE-_1

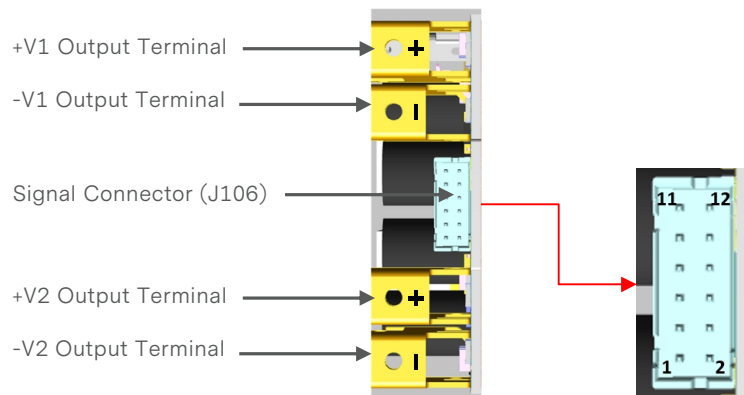

SECTION 3 MECHANICAL SPECIFICATIONS

3.9 Power / Signal Mating Connectors and Pin Types

Table 7. Mating Connectors for NP08 (or equivalent)	
Reference	Mating Connector or Equivalent
AC Input (Terminal block)	MFR: Phoenix Contact MPN: UWV 25 Conductor Range 10 - 2 AWG Tightening Torque 4.5N-m MAX
Earth Ground	Stud M6 Tighten to 6.5N-m MAX
Case Signal Connector - J1	Cvilux CI01 series 14 POS 0.079" (2.00mm) pitch (housing) Crimp Terminal AWG 24-30 Crimp Terminal Cvilux MPN: CI01T011
Case Comms Connector - J2	8Pin RJ45
Module Signal Connector - J106	Landwin 2050S1200 Housing Landwin 2053T011V Pin or JST PHDR-12VS Housing JST SPHD-002T-P0.5 (28-24) JST SPHD-001T-P0.5 (26-22)

MECHANICAL SPECIFICATIONS

3.10 Case LED Indicator Definitions

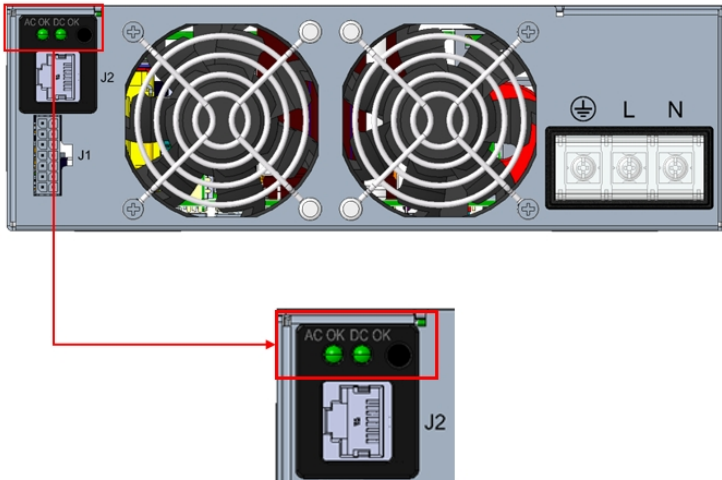

Conditions	AC OK LED	DC OK LED
No AC	OFF	OFF
AC Present, Outputs Inhibited (Case Global Inhibit)	ON	Blinking
AC Present, Outputs Inhibited (Module Isolated Inhibit)	ON	OFF
AC Present, Outputs Enabled	ON	ON
Output OCP / OVP / Fan Fault	ON	OFF

3.11 Module LED Indicator Definitions

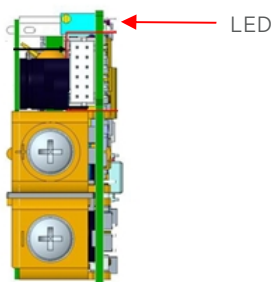

Conditions	LED
Module Inhibited	Blinking Green
Module Enabled	Solid Green
Module Faulted	Solid Red

SECTION 4 ENVIRONMENTAL SPECIFICATIONS

4.1 EMC Immunity

NP08 series power supply is designed to meet the following EMC immunity specifications.

Table 8. Environmental Specifications			
Test Items	Standard	Test Level	Criteria ¹
Conducted Emissions	EN 55011/CISPR11, FCC CFR47, Part 15, Subpart B	Class A. 150kHz to 30MHz	-
Radiated Emissions	EN 55011/CISPR11, FCC CFR47, Part 15, Subpart B	Class A. 30MHz to 1GHz	-
EMC Directive 2004/108/EC	EN 61000-6-4:2007/A1:2011	EMC - Part 6-4: Generic standards - Emission standard for industrial environments)	-
Voltage Fluctuations	EN 61000-3-11	-	-
Power Line Harmonics	EN 61000-3-12	-	-
Electro Static Discharge (ESD) Immunity	EN 61000-4-2	8kV contact, 15kV air	A
Radiated RF Immunity	EN 61000-4-3	Level 3 (10V/m) 80MHz to 1GHz	A
Electrical Fast Transients (EFT)	EN 61000-4-4	AC Power Port: +/-2kV I/O Signal Power Port: +/-0.5kV	A
Surges - Line to Line (DM) and Line to GND (CM)	EN 61000-4-5	2kV DM, 4kV CM	A
Conducted RF Immunity	EN 61000-4-6	Level 2 (3Vrms) 150kHz to 80MHz	A
Power Frequency Magnetic Field	EN 61000-4-8	Level 4 (30A/m) 50Hz, 60Hz	A
Voltage Dips & Interruptions	EN 61000-4-34 SEMI-F47	100% reduction, 0.5/0.6 cycle (10ms) 100% reduction, 1/1.2 cycle (20ms) 50% reduction, 10/12 cycle (200ms) 30% reduction, 25/30 cycle (500ms) 20% reduction, 50/60 cycle (1000ms) 20% reduction, 250/300 cycle (5000ms)	A A A A A A

Note 1 - Performance criteria are based on EN55024. According to the standards, performance criteria are defined as following:

- A - Normal performance during and after the test
- B - Temporary degradation, self-recoverable
- C - Temporary degradation, operator intervention required to recover the operation
- D - Permanent damage

SECTION 4 ENVIRONMENTAL SPECIFICATIONS

4.2 Safety Certifications

The NP08 series power supply is intended for inclusion in other equipment and the installer must ensure that it is in compliance with all the requirements of the end application. This product is only for inclusion by professional installers within other equipment and must not be operated as a stand alone product.

Standard	Agency	Description
UL 62368-1, CSA C22.2 No. 62368-1	UL + CUL	US and Canadian AV/ICT
EN 62368-1	-	European AV/ICT
IEC 62368-1	-	International AV/ICT
ANSI/AAMI ES60601-1 (2005 + C1:09 + A2:10) "3rd Ed"	-	US Medical
CAN/CSA-C22.2 No. 60601-1	-	Canadian Medical
EN 60601-1	-	European Elect. Equipment
IEC 60601-1	-	International Elect. Equipment
CB Certificate and Report (IEC 62368-1)	-	All CENELEC Countries
CE (LVD+RoHS), EN 62368-1	-	European Requirements
CCC (CQC Optional)	-	China Requirements

SECTION 4 ENVIRONMENTAL SPECIFICATIONS

4.3 EMI Emissions

The NP08 series has been designed to comply with the Class A limits of EMI requirements of EN55011 (FCC CFR47, Part 15, Subpart B) and CISPR 11 (EN55011) for emissions and relevant sections of EN61000 (IEC 61000) for immunity. The unit is tested at full load.

Conducted Emissions

The applicable standard for conducted emissions is EN55011 (FCC Part 15). Conducted noise can appear as both differential mode and common mode noise currents. Differential mode noise is measured between the two input lines, with the major components occurring at the supply fundamental switching frequency and its harmonics. Common mode noise, a contributor to both radiated emissions and input conducted emissions, is measured between the input lines and system ground and can be broadband in nature.

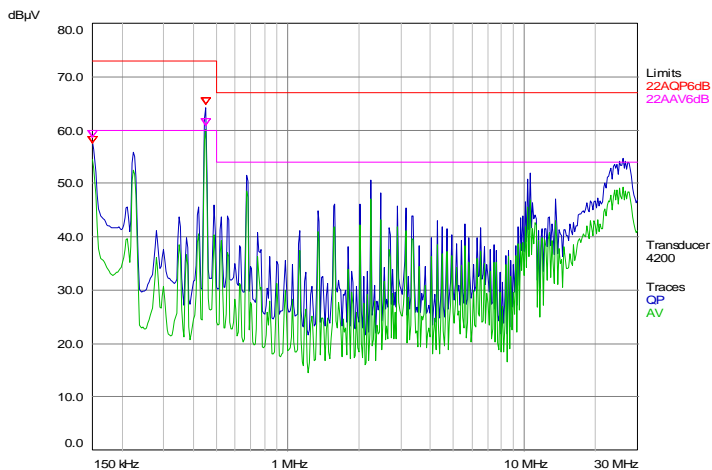

The NP08 series power supplies have internal EMI filters to ensure the converters' conducted EMI levels comply with EN55011 (FCC CFR47, Part 15, Subpart B) Class A and EN55011 (CISPR 11) class A limits. The EMI measurements are performed with resistive loads at maximum rated loading.

Sample of EN55011 Conducted EMI Measurement at 230Vac input.

Note: Red Line refers to Artesyn Quasi Peak margin, which is 5dB below the CISPR international limit. Pink Line refers to the Artesyn Average margin, which is 5dB below the CISPR international limit.

SECTION 4 ENVIRONMENTAL SPECIFICATIONS

4.4 Operating Temperature

The NP08 series forward fan models can operate with full performance from ambient temperature 0°C to 50°C. The reverse fan models can operate with full performance from ambient temperature 0°C to 35°C. The output power is derated linearly from 50°C to 70°C.

4.5 Storage and Shipping Temperature

The NP08 series power supply can be stored or shipped at temperatures between -40°C to +85°C.

4.6 Altitude

The NP08 series power supply is certified for safety spacing's requires for 3000 meters altitude. The power supply will not be damaged when stored at altitudes of up to 9144 meters above sea level.

4.7 Humidity

The NP08 series power supply can operate within specifications when subjected to a relative humidity from 20% to 90% non-condensing. The power supply can be stored in a relative humidity from 10% to 95% non-condensing.

4.8 Forced Air Cooling

The NP08 series includes internal cooling fans as part of the power supply assembly to provide forced air-cooling to maintain and control temperature of devices and ambient temperature in the power supply to appropriate levels.

The fan is controlled to run at the minimum speed required to cool the internal components. The fan control algorithm is smart enough to optimize the fan speed based on the thermal hot spots of the modules and case.

The power supply pressure vs airflow PQ curve is shown as below.

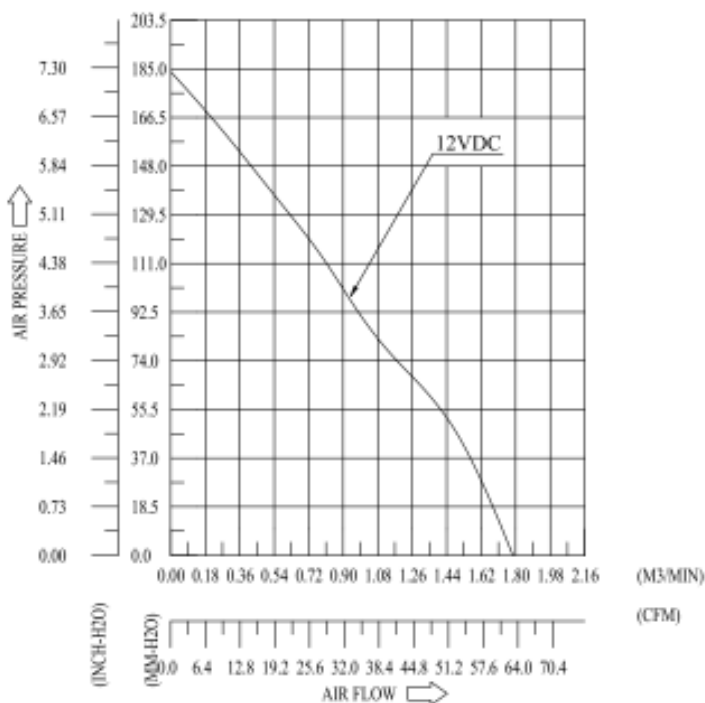

SECTION 4 ENVIRONMENTAL SPECIFICATIONS

4.9 Acoustic Noise

Noise	Condition
< 80 dBA	24 hours continuous operation (full performance)
< 65 dBA	80% load/30°C ambient
< 46 dBA	Modules are inhibited (standby mode)

4.10 Vibration

The NP08 series power supply passes the following vibration specifications.

The random vibration is tested per MIL-STD-810G, method 514.6, procedure I, category 4-11.

Non-Operating Random Vibration

Acceleration	6.0	gRMS
Frequency Range	10 to 2000	Hz
Duration	30	Mins
Direction	3 mutually perpendicular axis	

Operating Random Vibration

Acceleration	4.22	gRMS
Frequency Range	10 to 500	Hz
Duration	30	Mins
Direction	3 mutually perpendicular axis	

Non-Operating Sinusoidal Vibration

Acceleration	1.0	gRMS
Frequency Range	5 to 500	Hz
Duration	30	Mins
Direction	Sine vib 1 oct/min	

The non-operating vibration (packaged) is tested per IPC 9592B Class I; MIL-STD-810G, Method 514.6, Procedure I, Category 7, Table 514.6C-VII, General Exposure.

SECTION 4 ENVIRONMENTAL SPECIFICATIONS

4.11 Shock

The NP08 series power supply passes the following shock specifications.

The shock is tested per MIL-STD-810G, method 514.6, procedure I and II.

Non-Operating Shock

Acceleration	30	G
Duration	26	ms
Pulse	Square wave pulse	
Number of Shock	3 shocks in each of 6 faces	

Operating Shock

Acceleration	40	G
Duration	6	ms
Pulse	Half sine pulse	
Number of Shock	3 shocks in each of 6 faces	

SECTION 5 POWER AND CONTROL SIGNAL DESCRIPTIONS

5.1 AC Input Connector

This connector supplies the AC Mains to the NP08 series power supply.

- L - Line
- N - Neutral
-  - Chassis Ground

5.2 Case Signal Connector - J1

This connector is a 14-pin control signal header.

G_ACOK_E (Pin 1) & G_ACOK_C (Pin 8)

G_ACOK_E: Ground reference for ACOK signal.

G_ACOK_C: Programmable logic polarity. Default setting is active LOW signal.
Indicates the input supply voltage is within operational range of the power supply.

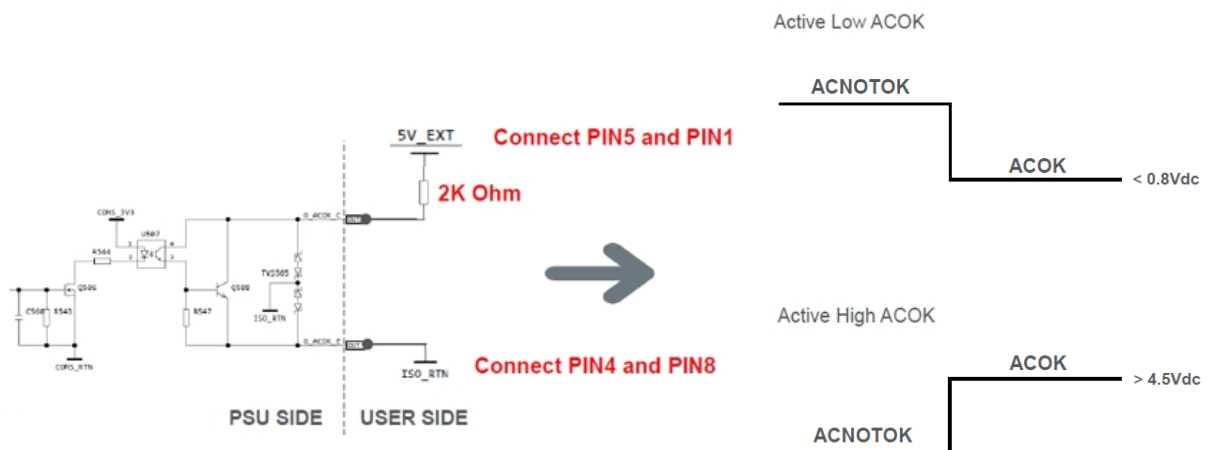

ISO_RTN1 (Pins 4, 7, 11, 12, 14)

Isolated supply return

5V_EXT (Pin 5)

Isolated 5V logic supply

5V_STBY (Pin 6) & 5V_STBY_RTN (Pin 13)

5V stand-by and return

SECTION 5 POWER AND CONTROL SIGNAL DESCRIPTIONS

G_PGOOD_E (Pin 2) & G_PGOOD_C (Pin 9)

G_PGOOD_E: Ground reference for PGOOD signal.

G_PGOOD_C: Programmable logic polarity. Default setting is active LOW signal.
Indicates the module output voltages are within regulation band.

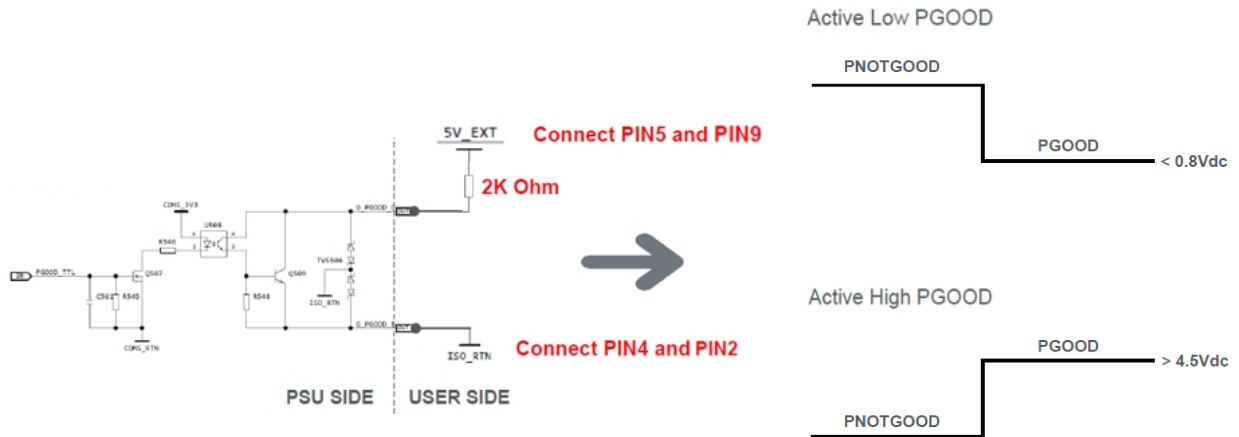

INH0 (Pin 3) & INH1 (Pin 10)

INH0: Global Inhibit Logic "0" signal functions to turn-off all modules simultaneously. Internally pulled-up to COM5_5V via 10k Ohm resistor.

INH1: Global Inhibit Logic "1" signal functions to turn-off all modules simultaneously. Internally pulled-down to ISO_RTN via 4.7k Ohm resistor.

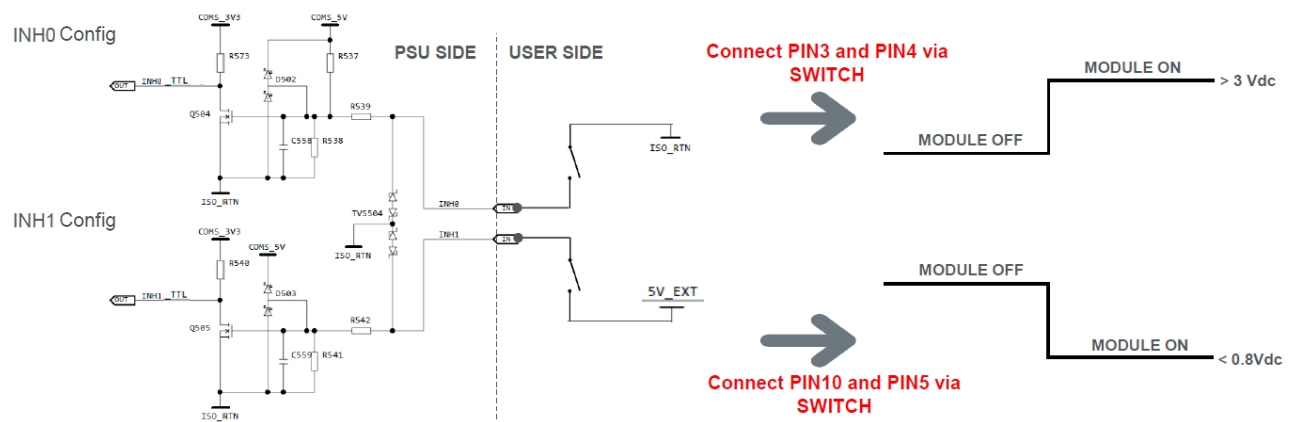

SECTION 5 POWER AND CONTROL SIGNAL DESCRIPTIONS

5.3 Case Connected Power Bus Connector - J2

This connector is a 8-pin control signal header.

RS485 A (Pin 1)

Communication lines for RS485 MODBUS protocol.

RS485 B (Pin 2)

Communication lines for RS485 MODBUS protocol.

ISO_RTNI (Pins 3, 4, 5, 6)

Isolated supply return.

+5V_Logic_Supply (Pin 7)

Isolated 5V logic supply.

+5V_Logic_Supply_Return (Pin 8)

Isolated supply return.

5.4 Single Output Module Signal Connector - J106

This connector is a 12-pin control signal header.

ISO_M_INHIBIT (Pin 1)

Active LOW signal, isolated signal to inhibit the module output. Add 1k ohm pull-up resistor to 5V external supply to reduce optocoupler bias current to 2.4mA.

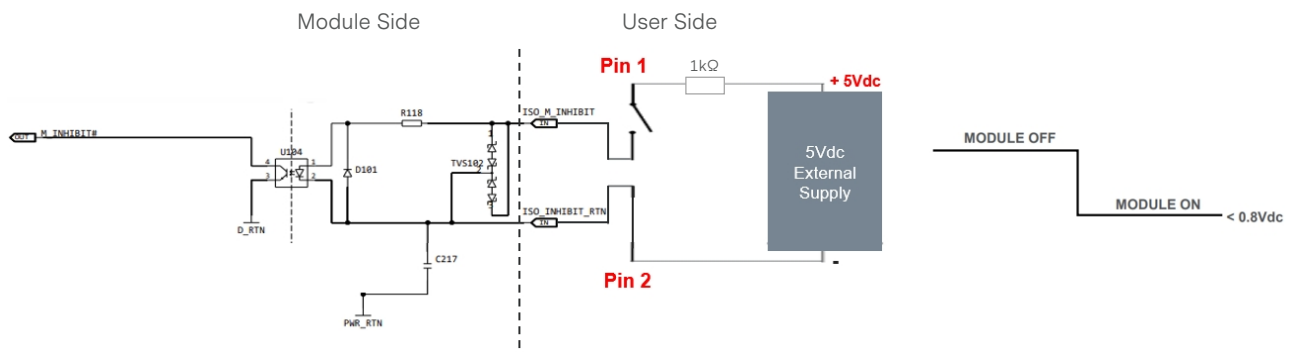

ISO_M_INHIBIT_RTNI (Pin 2)

Ground reference for ISO_M_INHIBIT signal.

SECTION 5 POWER AND CONTROL SIGNAL DESCRIPTIONS

ISO_POWER_GOOD (Pin 3)

Active HIGH signal, isolated signal that indicates module output voltage or current is within regulation. 5V external DC source is needed. Connect a 2k ohm resistor between +5V and Pin 3.

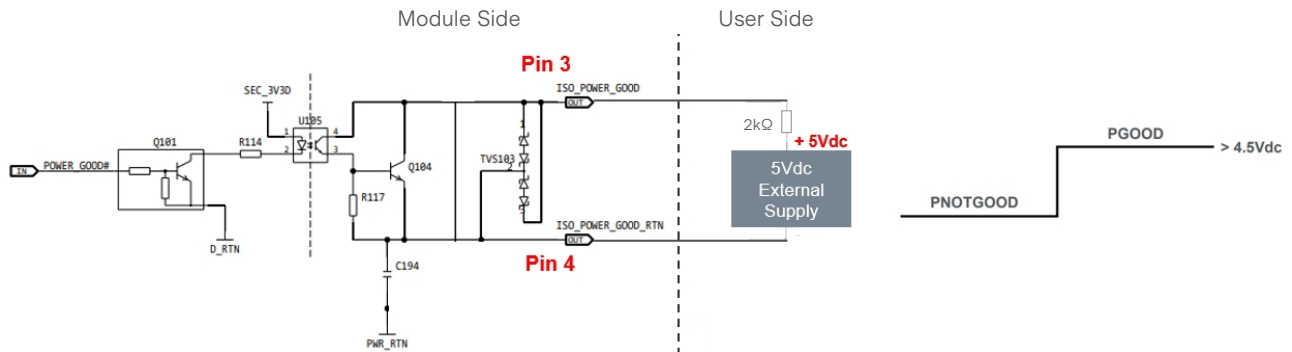

ISO_POWER_GOOD_RTN (Pin 4)

Ground reference for ISO_POWER_GOOD.

0-10V_VI_PROG (Pin 5)

Used to control the output voltage by applying between 0 to 10V to this pin. This pin will function when the module is configured to Analog Voltage Source (AVS) mode.

Used to control the output current by applying between 0 to 10V to this pin. This pin will function when the module is configured to Analog Current Source (ACS) mode.

0-5V_VI_PROG (Pin 6)

Used to control the output voltage by applying between 0 to 5V to this pin. This pin will function when the module is configured to Analog Voltage Source (AVS) mode.

Used to control the output current by applying between 0 to 5V to this pin. This pin will function when the module is configured to Analog Current Source (ACS) mode.

VI_TRIM_EN# (Pin 7)

Connecting this pin to D_RTN will enable the trimmer potentiometer. This pin will function when the module is configured to Digital Voltage Source (DVS) or Digital Current Source (DCS) modes.

D_RTN (Pin 8)

Ground reference for 0-10_VI_PROG & 0-5_VI_PROG signals.

SECTION 5 POWER AND CONTROL SIGNAL DESCRIPTIONS

ISHARE (Pin 9)

The ISHARE signal is used for active current sharing between multiple paralleled modules. For single module, the ISHARE Voltage level at no load is 0.4V typ., and at full load is 8.4V typ. with linear function. The diagram showing as below.

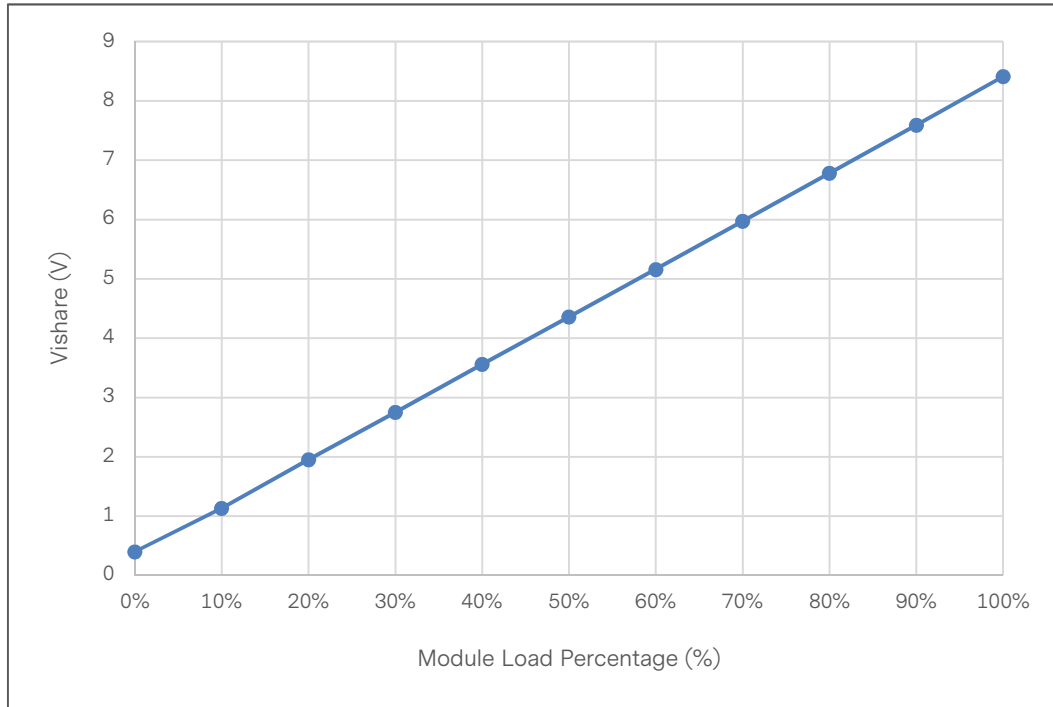

ISHARE_RTN (Pin 10)

Ground reference for ISHARE signal.

RS+ (Pin 11)

Signal used for module output voltage positive remote sense.

RS- (Pin 12)

Signal used for module output voltage negative remote sense.

SECTION 6 MODBUS SPECIFICATIONS

6.1 NP08 Series MODBUS General Instructions

The NP08 series is compliant with the MODBUS application protocol for monitoring and control of the power supply via the RS485 communication port.

Equipment Setup

The following is typical RS485 MODBUS communication setup:

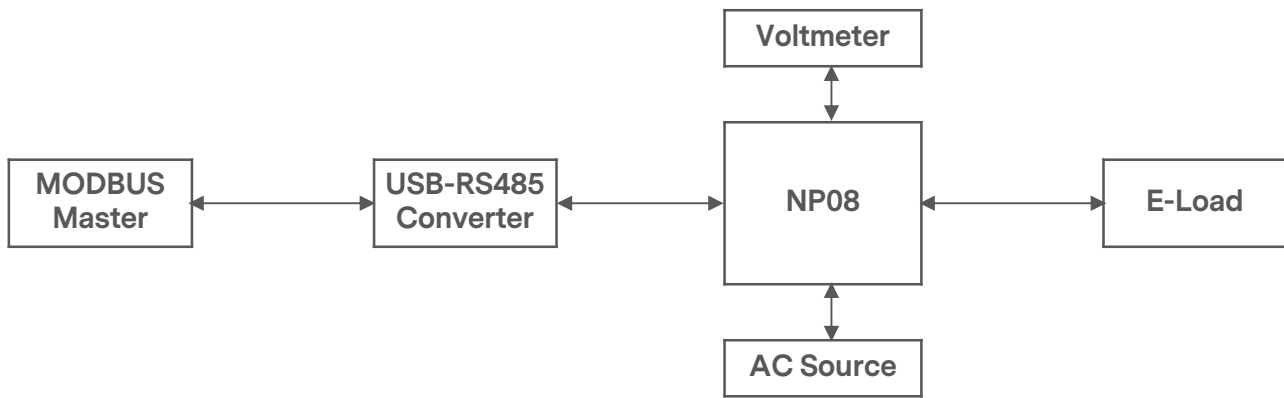

Serial Configuration

The Baud Rate (Data Rate) can be set by the MODBUS register (0xAB).

Parameter	Settings
Data Rate	115200 (Default)
Data Bits	8
Parity	Even
Stop Bits	1

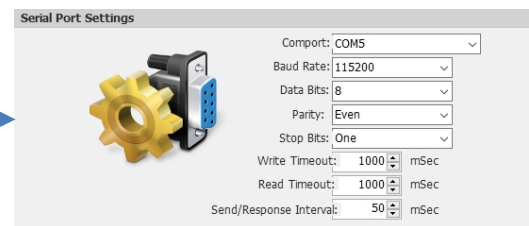

The Data Rate is configurable using the Baud Rate Config Register (0xAB).

Register Address 0xAB	
Value (Hex)	Baud Rate Configuration
0	9600
1	19200
2	38400
3	115200 (Default)

SECTION 6 MODBUS SPECIFICATIONS

Device Addressing

The Default MODBUS Address configuration is 0xC0.

The MODBUS address is configurable using the device address register 0xAA, and the configurable range is from 0x01 to 0xF0.

Broadcast command (0x00) is supported.

Reporting Accuracy

Parameter Type	Reporting Function	Hex Address	Command Name	Accuracy Range	
				0% to 20% Load	20% to 100% Load
Module Output	Output Voltage	0xB0	MODULE_READ_VOUT	$(\pm 0.5\% \text{ of } V_{set}) + (\pm 0.5\% \text{ of } V_{nom})$	
Module Output	Output Current	0xB1	MODULE_READ_IOUT	$(\pm 1.0\% \text{ of } I_{set}) + (\pm 1.0\% \text{ of } I_{rated})$	
Module Output	Output Power	0xB2	MODULE_READ_POUT	Fixed $\pm 5\%$ of rated max output power	$\pm 5\%$
Case Input	Input Voltage	0xB4	CASE_INPUT_VOLTAGE	No requirements	$\pm 2\%$
Case Input	Input Current	0xB5	CASE_INPUT_CURRENT	No requirements	$\pm 5\%$
Case Input	Input Power	0xB6	CASE_INPUT_POWER	No requirements	$\pm 3\%$
Case Thermal	Temperature	0xB7	CASE_TEMP1 – BST_FET1	$\pm 5^{\circ}\text{C}$	
Case Thermal	Temperature	0xB8	CASE_TEMP2 – BST_FET2	$\pm 5^{\circ}\text{C}$	
Case Thermal	Temperature	0xB9	CASE_TEMP3 – LLC1	$\pm 5^{\circ}\text{C}$	
Case Thermal	Temperature	0xBA	CASE_TEMP5 – OTP_SYNC	$\pm 5^{\circ}\text{C}$	
Case Thermal	Temperature	0xBB	CASE_TEMP6 – AUXILLARY1	$\pm 5^{\circ}\text{C}$	
Case Thermal	Temperature	0xBC	CASE_TEMP7 – AUXILLARY2	$\pm 5^{\circ}\text{C}$	
Case Thermal	Temperature	0xBD	CASE_TEMP8 – AMBIENT	$\pm 2^{\circ}\text{C}$	
Module Thermal	Temperature	0xB7	MODULE_TEMP1 – SYNC	$\pm 5^{\circ}\text{C}$	
Module Thermal	Temperature	0xB8	MODULE_TEMP2 – BUCK	$\pm 5^{\circ}\text{C}$	
Module Thermal	Temperature	0xB9	MODULE_TEMP3 – FWL	$\pm 5^{\circ}\text{C}$	
Module Thermal	Temperature	0xBA	MODULE_TEMP4 – AMBIENT	$\pm 2^{\circ}\text{C}$	

SECTION 6 MODBUS SPECIFICATIONS

SAVE_COMMAND [W]

The SAVE_COMMAND (0x8A) is used to manually save the following registers.

Note: MODULE_CONFIG_VALID (0x400A) should be in 0x01 before executing save command to store below register value.

Case Commands		Module Commands	
MODBUS Address	Data	MODBUS Address	Data
0x96	PSU_OUTPUT_OV_MULTIPLIER	0x84	MODULE_OPERATION
0xAA	PSU_OUTPUT_OC_MULTIPLIER	0x85	MODULE_VREF_TRIM
0xAB	BAUD_RATE_CONFIG	0x86	MODULE_IREF_TRIM
0x400A	MODULE_CONFIG_VALID	0x87	MODULE_CONFIG
		0x88	MODULE_CLEAR_FAULTS
		0x8B	DSP_PROG_RESCALE_PROFILE
		0x8C	VPROG_RESCALE_MIN
		0x8D	VPROG_RESCALE_MAX
		0x8E	VPROG_RESCALE_PT1
		0x8F	VPROG_RESCALE_PT2
		0x90	VPROG_TURN_ON_POINT
		0x91	Iprog_RESCALE_MIN
		0x92	Iprog_RESCALE_MAX
		0x93	Iprog_RESCALE_PT1
		0x94	Iprog_RESCALE_PT2
		0x95	Iprog_TURN_ON_POINT
		0x97	VREF_MAX_LIMIT
		0x98	IREF_MAX_LIMIT
		0x99	MODULE_VOUT_OV_FAULT_LIMIT_MULTIPLIER
		0x9A	MODULE_VOUT_OV_WARN_LIMIT_MULTIPLIER
		0x9B	MODULE_VOUT_UV_FAULT_LIMIT_MULTIPLIER
		0x9C	MODULE_VOUT_UV_WARN_LIMIT_MULTIPLIER
		0x9D	MODULE_OC_FAULT_LIMIT_MULTIPLIER
		0x9E	CV_LIMIT
		0xA4	MODULE_POWER_GOOD_ON
		0xA6	MODULE_POWER_GOOD_OFF
		0xA8	MODULE_VOLTAGE_RISE_SETTING
		0xA9	MODULE_CURRENT_RISE_SETTING
		0xAC	MODULE_IO_ACTIVE_LEVEL_LOGIC
		0xAD	MODULE_LOAD_TYPE

SECTION 6 MODBUS SPECIFICATIONS

6.2 NP08 Case Supported MODBUS Command List

Command Code	Command Name	Default Value (Hex)	Access Type	Data Bytes	Data Format	Description
00h	CASE_MODEL_ID	-	R	4	ASCII	Default: 08W1
02h	CASE_MFR_MODEL	-	R	20	ASCII	Default: 83-108-0001W
0Ch	CASE_MFR_LOCATION	-	R	20	ASCII	
16h	CASE_MFR_DATE	-	R	8	ASCII	
1Ah	CASE_MFR_SERIAL	-	R	20	ASCII	
24h	CASE_HW_REVISION	-	R	4	ASCII	
26h	CASE_FW_REVISION	-	R	18	ASCII	
70h	CASE_STATUS_WORD	-	R	2	Bitmapped	Summary of the unit's fault condition.
	b15 - VOUT					Asserts when any of the bit is set in STATUS_VOUT register.
	b14 - IOUT					Asserts when any of the bit is set in STATUS_IOUT register.
	b13 - INPUT					Asserts when any of the bit is set in STATUS_INPUT register.
	b12 - MFR_SPECIFIC					Asserts when any of the bit is set in STATUS_MFR_SPECIFIC register.
	b11					Reserved
	b10 - FANS					Asserts when any of the bit is set in STATUS_FAN_1_2 register.
	b9:3					Reserved
	b2 - TEMPERATURE					Asserts when any of the bit is set in STATUS_TEMPERATURE register.
71h	b1:0					Reserved
	CASE_STATUS_INPUT	-	R	2	Bitmapped	
	b15:8					Reserved
	b7 - VIN_OV_FAULT					Asserts when there is an Input Overvoltage Fault. Auto recoverable.
	b6:5					Reserved
72h	b4 - VIN_UV_FAULT					Asserts when there is an Input Under Voltage Fault. Auto recoverable.
	b3:0					Reserved
	CASE_STATUS_VOUT	-	R	2	Bitmapped	
73h	b15:3					Reserved
	b2 - TON_MAX_FAULT					Device is unable to reach the target output within the stated power up time. This Can be cleared by Input Power Recycle.
	b1:0					Reserved
73h	CASE_STATUS_IOUT	-	R	2	Bitmapped	
	b15:8					Reserved
	b7 - IOUT_OC_FAULT					Asserts when there is an Output Overcurrent Fault. This Can be cleared by Input Power Recycle.
73h	b6:0					Reserved

SECTION 6 MODBUS SPECIFICATIONS

The NP08 Case Supported MODBUS Command List

Command Code	Command Name	Default Value	Access Type	Data Bytes	Data Format	Description
74h	CASE_STATUS_MFR_SPECIFIC	-	R	2	Bitmapped	
	b15:13					
	b12 - BOOST_OVP1					Bulk Voltage 1 is above overvoltage protection level. This can be cleared by Input Power Recycle.
	b11:10					Reserved
	b9 - BOOST_UVP1					Bulk voltage 1 is below under voltage protection level. This Can be cleared by Input Power Recycle.
	b8 - BOOST_BAD					Asserted when bulk voltage is out of range
	b7 - ISO_SUPPLY_MON					Asserted when 80V output is out of range
	b6:3					Reserved
	b2 - PRIMARY_OC_FAULT					Primary Overcurrent Fault. Auto recoverable.
b1:0						
75h	CASE_MODULE_DETECTION	-	R	2	Bitmapped	
	b15 - MODULE_16					Asserts when slot 16 is detected
	b14 - MODULE_15					Asserts when slot 15 is detected
	b13 - MODULE_14					Asserts when slot 14 is detected
	b12 - MODULE_13					Asserts when slot 13 is detected
	b11 - MODULE_12					Asserts when slot 12 is detected
	b10 - MODULE_11					Asserts when slot 11 is detected
	b9 - MODULE_10					Asserts when slot 10 is detected
	b8 - MODULE_9					Asserts when slot 9 is detected
	b7 - MODULE_8					Asserts when slot 8 is detected
	b6 - MODULE_7					Asserts when slot 7 is detected
	b5 - MODULE_6					Asserts when slot 6 is detected
	b4 - MODULE_5					Asserts when slot 5 is detected
	b3 - MODULE_4					Asserts when slot 4 is detected
	b2 - MODULE_3					Asserts when slot 3 is detected
	b1 - MODULE_2					Asserts when slot 2 is detected
b0 - MODULE_1					Asserts when slot 1 is detected	

SECTION 6 MODBUS SPECIFICATIONS

The NP08 Case Supported MODBUS Command List

Command Code	Command Name	Default Value	Access Type	Data Bytes	Data Format	Description
76h	CASE_STATUS_TEMPERATURE	-	R	2	Bitmapped	
	b15					
	b14 - BOOST_FET2_OT_FAULT					Primary Boost 2 Temperature is above Over temperature fault limit. Auto recoverable.
	b13 - BOOST_FET1_OT_FAULT					Primary Boost 1 Temperature is above Over temperature fault limit Auto recoverable.
	b12 - LLC_FET1_OT_FAULT					Primary LLC 1 Temperature is above Over temperature fault limit. Auto recoverable.
	b11 - AUXILIARY2_OT_FAULT					ISO Auxiliary 2 Temperature is above Over temperature fault limit Auto recoverable
	b10 - AUXILIARY1_OT_FAULT					ISO Auxiliary 1 Temperature is above Over temperature fault limit Auto recoverable
	b9 - AMBIENT_OT_FAULT					ISO Ambient Temperature is above Over temperature fault limit Auto recoverable
	b8 - SYNC_OT_FAULT					ISO Sync Rect Temperature is above Over temperature fault limit Auto recoverable
	b7 - OT_FAULT					Asserts when any of the bit [15:8] in STATUS_TEMPERATURE register is set. Auto recoverable.
	b6:0					
77h	CASE_STATUS_FANS_1_2	-	R	2	Bitmapped	
	b15:8					
	b7 - FAN_STATUS_FAN_FAULT_1					Asserts when fan1 has fault.
	b6 - FAN_STATUS_FAN_FAULT_2					Asserts when fan2 has fault.
	b5:4					Not supported
	b3 - FAN_SPEED_OVERRIDDEN_1					Asserts when user override speed is dominant over fan control. De-asserts when override duty is lower than the control duty or is set to 0% duty.
	b2:0					

SECTION 6 MODBUS SPECIFICATIONS

The NP08 Case Supported MODBUS Command List

Command Code	Command Name	Default Value	Access Type	Data Bytes	Data Format	Description
78h	CASE_STATUS_CML	-	R	2	Bitmapped	Determines which module has encountered communication timeout.
	b15:8					Reserved
	b7					MODULE8_COMMS_TIMEOUT
	b6					MODULE7_COMMS_TIMEOUT
	b5					MODULE6_COMMS_TIMEOUT
	b4					MODULE5_COMMS_TIMEOUT
	b3					MODULE4_COMMS_TIMEOUT
	b2					MODULE3_COMMS_TIMEOUT
	b1					MODULE2_COMMS_TIMEOUT
b0					MODULE1_COMMS_TIMEOUT	
82h	FAN1_DUTY_OVERRIDE	-	R/W	2		x1 Default: 0% Range: 0% to 100%
8Ah	SAVE_COMMAND	-	W			Baud Rate, IO Polarity, Device Address, Module Configurations. 0x01 - To issue save command
96h	IO_POLARITY	-	R/W	2	Bitmapped	Used to change the active levels of POWER_GOOD and ACOK.
	b15:2					Reserved
	b1 - ACOK_ACTIVE_LEVEL					0 - ACOK Active Level is Active High 1 - ACOK Active Level is Active Low
	b0 - POWER_GOOD_ACTIVE_LEVEL					0 - POWER GOOD Active Level is Active High 1 - POWER GOOD Active Level is Active Low
AAh	DEVICE_ADDRESS	-	R/W	2		Default: 192 (0xC0) Range: 1 (0x01) to 255 (0xFF) Broadcast command (0x00) is supported.
ABh	BAUD_RATE_CONFIG	-	R/W	2		
B4h	CASE_INPUT_VOLTAGE	-	R	2	Varies	x1
B5h	CASE_INPUT_CURRENT	-	R	2	Varies	x1000
B6h	CASE_INPUT_POWER	-	R	2	Varies	x10
B7h	CASE_TEMP1 - BST_FET1	-	R	2	Varies	x100
B8h	CASE_TEMP2 - BST_FET2	-	R	2	Varies	x100
B9h	CASE_TEMP3 - LLC1	-	R	2	Varies	x100
BAh	CASE_TEMP5 - OTP_SYNC	-	R	2	Varies	x100
BBh	CASE_TEMP6 - AUXILLARY1	-	R	2	Varies	x100
BCh	CASE_TEMP7 - AUXILLARY2	-	R	2	Varies	x100
BDh	CASE_TEMP8 - AMBIENT	-	R	2	Varies	x100
BEh	CASE_RPM_FAN0	-	R	2	Varies	x1
BFh	CASE_RPM_FAN1	-	R	2	Varies	x1
C2h	CASE_CURRENT_RUNTIME	-	R	4	Varies	x1
C4h	CASE_TOTAL_RUNTIME	-	R	4	Varies	x1

SECTION 6 MODBUS SPECIFICATIONS

The NP08 Case Supported MODBUS Command List

Command Code	Command Name	Default Value	Access Type	Data Bytes	Data Format	Description
121h	CASE_PRI_PMON_RAW_PIN	-	R	2	Varies	x10
122h	CASE_PRI_PMON_RAW_PIN_AVE	-	R	2	Varies	x10
123h	CASE_PRI_PMON_RAW_VIN	-	R	2	Varies	x1
124h	CASE_PRI_PMON_RAW_IIN	-	R	2	Varies	x1000
125h	CASE_PRI_PMON_RAW_LINE_FREQ	-	R	2	Varies	x1 If value is 0, disable reporting of frequency from PMON
126h	CASE_PRI_PMON_DC_INPUT_STATUS	-	R	2	Varies	x1
127h	CASE_PRI_PMON_RAW_ITHD_A	-	R	2	Varies	x1 Scaling Factor: 100/65536
128h	CASE_PRI_PMON_RAW_ITHD_B	-	R	2	Varies	x1 Scaling Factor: 100/65536
129h	CASE_PRI_PMON_RAW_POWER_FACTOR	-	R	2	Varies	x1 Scaling Factor: 1/256
136h	CASE_PROGRAMMABLE_HOLDUP	-	R/W	2	Varies	x1 Value of programmable holdup in milliseconds
137h	CASE_ONE_FAULT_SHUTDOWN	-	R/W	2	Bitmapped	0 - Disabled one fault shutdown 1 - Enabled one fault shutdown
1EFh	BLACKBOX_PAGE_SELECTOR	-	R/W	2	Varies	x1 Page selector for blackbox information Valid range: 1 to 4
2100h	GROUP1_VREF	-	R/W	2	Varies	x100 Default: Nominal Voltage Range: 5% to 120% of Nominal Voltage
2101h	GROUP1_IREF	-	R/W	2	Varies	x100 Default: Nominal Current Range: 0% to 100% of Nominal Current
2102h	GROUP1_OPERATION	80	R/W	2	Bitmapped	Default: 0x80 - ON Valid: 0x00 - OFF
2110h	GROUP2_VREF	-	R/W	2	Varies	x100 Default: Nominal Voltage Range: 5% to 120% of Nominal Voltage
2111h	GROUP2_IREF	-	R/W	2	Varies	x100 Default: Nominal Current Range: 0% to 100% of Nominal Current
2112h	GROUP2_OPERATION	80	R/W	2	Bitmapped	Default: 0x80 - ON Valid: 0x00 - OFF
2120h	GROUP3_VREF	-	R/W	2	Varies	x100 Default: Nominal Voltage Range: 5% to 120% of Nominal Voltage
2121h	GROUP3_IREF	-	R/W	2	Varies	x100 Default: Nominal Current Range: 0% to 100% of Nominal Current
2122h	GROUP3_OPERATION	80	R/W	2	Bitmapped	Default: 0x80 - ON Valid: 0x00 - OFF

SECTION 6 MODBUS SPECIFICATIONS

The NP08 Case Supported MODBUS Command List

Command Code	Command Name	Default Value	Access Type	Data Bytes	Data Format	Description
2130h	GROUP4_VREF	-	R/W	2	Varies	x100 Default: Nominal Voltage Range: 5% to 120% of Nominal Voltage
2131h	GROUP4_IREF	-	R/W	2	Varies	x100 Default: Nominal Current Range: 0% to 100% of Nominal Current
2132h	GROUP4_OPERATION	80	R/W	2	Bitmapped	Default: 0x80 - ON Valid: 0x00 - OFF
2140h	GROUP5_VREF	-	R/W	2	Varies	x100 Default: Nominal Voltage Range: 5% to 120% of Nominal Voltage
2141h	GROUP5_IREF	-	R/W	2	Varies	x100 Default: Nominal Current Range: 0% to 100% of Nominal Current
2142h	GROUP5_OPERATION	80	R/W	2	Bitmapped	Default: 0x80 - ON Valid: 0x00 - OFF
2150h	GROUP6_VREF	-	R/W	2	Varies	x100 Default: Nominal Voltage Range: 5% to 120% of Nominal Voltage
2151h	GROUP6_IREF	-	R/W	2	Varies	x100 Default: Nominal Current Range: 0% to 100% of Nominal Current
2152h	GROUP6_OPERATION	80	R/W	2	Bitmapped	Default: 0x80 - ON Valid: 0x00 - OFF
2160h	GROUP7_VREF	-	R/W	2	Varies	x100 Default: Nominal Voltage Range: 5% to 120% of Nominal Voltage
2161h	GROUP7_IREF	-	R/W	2	Varies	x100 Default: Nominal Current Range: 0% to 100% of Nominal Current
2162h	GROUP7_OPERATION	80	R/W	2	Bitmapped	Default: 0x80 - ON Valid: 0x00 - OFF
2170h	GROUP8_VREF	-	R/W	2	Varies	x100 Default: Nominal Voltage Range: 5% to 120% of Nominal Voltage
2171h	GROUP8_IREF	-	R/W	2	Varies	x100 Default: Nominal Current Range: 0% to 100% of Nominal Current
2172h	GROUP8_OPERATION	80	R/W	2	Bitmapped	Default: 0x80 - ON Valid: 0x00 - OFF

SECTION 6 MODBUS SPECIFICATIONS

The NP08 Case Supported MODBUS Command List

Command Code	Command Name	Default Value	Access Type	Data Bytes	Data Format	Description
400Ah	MODULE_CONFIG_VALID	-	R/W	2	Bitmapped	Determines whether module config to use is from case internal memory (0x01) or from module internal default (0x00).
400Bh	MODULE_GROUP1		R/W	2	Bitmapped	Bitmap of modules part of group 1
400Ch	MODULE_GROUP2		R/W	2	Bitmapped	Bitmap of modules part of group 2
400Dh	MODULE_GROUP3		R/W	2	Bitmapped	Bitmap of modules part of group 3
400Eh	MODULE_GROUP4		R/W	2	Bitmapped	Bitmap of modules part of group 4
400Fh	MODULE_GROUP5		R/W	2	Bitmapped	Bitmap of modules part of group 5
4010h	MODULE_GROUP6		R/W	2	Bitmapped	Bitmap of modules part of group 6
4011h	MODULE_GROUP7		R/W	2	Bitmapped	Bitmap of modules part of group 7
4012h	MODULE_GROUP8		R/W	2	Bitmapped	Bitmap of modules part of group 8
4013h	ONE_FAULT_SHUTDOWN_GROUP_ENABLE		R/W	2	Bitmapped	Determines which module group has enabled one fault shutdown feature
	b15:8					Reserved
	b7					MODULE_GROUP8
	b6					MODULE_GROUP7
	b5					MODULE_GROUP6
	b4					MODULE_GROUP5
	b3					MODULE_GROUP4
	b2					MODULE_GROUP3
	b1					MODULE_GROUP2
	b0					MODULE_GROUP1

MODULE_GROUPx 400Bh to 4012h commands format, take 400Bh as an example:

Command Code	Command Name	Default Value	Access Type	Data Bytes	Data Format	Description
400Bh	MODULE_GROUP1		R/W	2	Bitmapped	Determines which module belongs to the group.
	b15:8					Reserved
	b7					MODULE8
	b6					MODULE7
	b5					MODULE6
	b4					MODULE5
	b3					MODULE4
	b2					MODULE3
	b1					MODULE2
	b0					MODULE1

SECTION 6 MODBUS SPECIFICATIONS

6.3 NP08 Series Module Supported MODBUS Command List

The module MODBUS command format is Module ID + Hex command code.

Module's Address Table:

Module	Offset Address (ID)
Module1	0x1000
Module2	0x1100
Module..	...
Module16	0x1F00

The NP08 Module Supported MODBUS Command List

Command Code	Command Name	Default Value (Hex)	Access Type	Data Bytes	Data Format	Description
00h	MODULE_MODEL_ID	-	R	4	ASCII	Varies
02h	MODULE_MFR_MODEL	-	R	20	ASCII	Varies
0Ch	MODULE_MFR_LOCATION	-	R	20	ASCII	Default: LAGUNA, PHILIPPINES
16h	MODULE_MFR_DATE	-	R	8	ASCII	Default: DD-MM-YY
1Ah	MODULE_MFR_SERIAL	-	R	20	ASCII	Default: MMMMWSSSSRRL
24h	MODULE_HW_REVISION	-	R	4	ASCII	Default: RR
26h	MODULE_FW_REVISION	-	R	8	ASCII	Default: 00.00
2Fh	MODULE_MFR_VOUT_MIN	-	R	2	Varies	x100, 5% of nominal voltage
30h	MODULE_MFR_VOUT_MAX	-	R	2	Varies	X100, 120% of nominal voltage
31h	MODULE_MFR_IOUT_MAX	-	R	2	Varies	x100
32h	MODULE_FW_REVISION	-	R	2	Varies	x1
70h	MODULE_STATUS_WORD	-	R	2	Bitmapped	Summary of the unit's fault condition.
	b15 - VOUT					Asserts when any of the bit is set in STATUS_VOUT register.
	b14 - IOUT					Asserts when any of the bit is set in STATUS_IOUT register.
	b13 - INPUT					Asserts when any of the bit is set in STATUS_INPUT register.
	b12					
	b11 - POWER_GOOD					Asserts when PSU is in off state or fault detected. Logic can be inverted when POWER_GOOD_ACTIVE_LEVEL is set.
	b10:3					Reserved
	b2 - TEMPERATURE					Asserts when any of the bit is set in STATUS_TEMPERATURE register.
71h	b1:0					Reserved
	MODULE_STATUS_INPUT	-	R	2	Bitmapped	
	b15:6					Reserved
	b5 - ISO_VOUT_BAD					Asserts when there is an input Under Voltage Fault Cleared by CLEAR_FAULT command.
	b4 - VIN_UV_FAULT					Asserts when there is an input Under Voltage Fault Cleared by CLEAR_FAULT command.
b3:0					Reserved	

SECTION 6 MODBUS SPECIFICATIONS

The NP08 Module Supported MODBUS Command List

Command Code	Command Name	Default Value	Access Type	Data Bytes	Data Format	Description
72h	CASE_STATUS_VOUT	-	R	2	Bitmapped	
	b15 - VOUT_SC_FAULT_1					Asserts when there is an Output Short Circuit 1 Fault. This can be cleared by CLEAR_FAULT command.
	b14 - BUCK_TON_MAX_FAULT					Buck is unable to reach the target output within the stated power up. This can be cleared by input power recycle.
	b13 - ISO_TON_MAX_FAULT					ISO is unable to reach the target output within the stated power up. This can be cleared by input power recycle.
	b12 - RMT_SENSE_SC_FAULT					Asserts when there is a Remote Sense Short Circuit Fault. This can be cleared by CLEAR_FAULT command.
	b11 - VOUT_SC_FAULT_2					Asserts when there is an Output Short Circuit 2 Fault. This can be cleared by CLEAR_FAULT command.
	b10:8					
	b7 - VOUT_OV_FAULT					Asserts when there is an Output Over Voltage Fault. This can be cleared by CLEAR_FAULT command.
	b6 - VOUT_OV_WARNING					Asserts when there is an Output Over Voltage Warning
	b5 - VOUT_UV_WARNING					Asserts when there is an Output Under Voltage Warning
	b4 - VOUT_UV_FAULT					Asserts when there is an Output Under Voltage Fault. This can be cleared by CLEAR_FAULT command.
	b3					
	b2 - TON_MAX_FAULT					Device is unable to reach the target output within the stated power up. This can be cleared by input power recycle.
	b1:0					
73h	CASE_STATUS_IOUT	-	R	2	Bitmapped	
	b15:8					
	b7 - IOUT_OC_FAULT					Asserts when there is an Output Overcurrent Fault. This Can be cleared by Input Power Recycle.
	b6:0					

SECTION 6 MODBUS SPECIFICATIONS

The NP08 Module Supported MODBUS Command List

Command Code	Command Name	Default Value	Access Type	Data Bytes	Data Format	Description
76h	MODULE_STATUS_TEMPERATURE	-	R	2	Bitmapped	
	b15 - SYNC_OT_FAULT					Sync Temperature is above over temperature fault limit. Auto recoverable
	b14 - BUCK_OT_FAULT					Buck Temperature is above over temperature fault limit. Auto recoverable
	b13 - FWL_OT_FAULT					Freewheel Temperature is above over temperature fault limit. Auto recoverable
	b12:8					
	b7 - OT_FAULT					Asserts when any of the bit [15:13] in STATUS_TEMPERATURE register is set. Auto recoverable.
	b6:0					
84h	MODULE_OPERATION	-	R/W	2	Bitmapped	Used to turn the module on and off.
	b15:8					
	b7 - MODULE_ON					0 - Module Off 1 - Module On
	b6:0					
85h	MODULE_VREF_TRIM	-	R/W	2	Varies	x100
86h	MODULE_IREF_TRIM	-	R/W	2	Varies	x100
87h	MODULE_CONFIG	-	R/W	2	Bitmapped	Used to configure the mode of the module.
	b15:3					
	b2 - OC_PROTECTION_MODE					0 - CC Mode 1 - Latch Mode
	b1 - OPERATION_MODE					0 - Current Source Mode 1 - Voltage Source Mode
	b0 - PSU_OUTPUT_CONTROL_MODE					0 - Analog Mode 1 - Digital Mode
88h	MODULE_CLEAR_FAULTS	-	W	2		0x00: disable (default) 0x01: clear all latching faults
8Bh	DSP_PROG_RESCALE_PROFILE	-	R/W	2		Default: 0x02 0x00 - Profile 1 0x01 - Profile 2 0x02 - Profile 3
8Ch	VPROG_RESCALE_MIN	-	R/W	2	Varies	x100 Default: 5% of Nominal Voltage Range: 5% of Nominal Voltage to VPROG_RESCALE_MAX
8Dh	VPROG_RESCALE_MAX	-	R/W	2	Varies	x100 Default: 120% of Nominal Voltage Range: VPROG_RESCALE_MIN to 120% of Nominal Voltage
8Eh	VPROG_RESCALE_PT1	-	R/W	2	Varies	x100 Default: 0.41V Range: VPROG_TURN_ON_POINT to 10V

SECTION 6 MODBUS SPECIFICATIONS

The NP08 Module Supported MODBUS Command List

Command Code	Command Name	Default Value	Access Type	Data Bytes	Data Format	Description
8Fh	VPROG_RESCALE_PT2	-	R/W	2	Varies	x100 Default: 10V Range: VPROG_RESCALE_PT1 to 10V
90h	VPROG_TURN_ON_POINT	-	R/W	2	Varies	x100 Default: 0.41V Range: 0.41V to 10V
91h	IPROG_RESCALE_MIN	-	R/W	2	Varies	x100 Default: 0A Range: 0A to IPROG_RESCALE_MAX
92h	IPROG_RESCALE_MAX	-	R/W	2	Varies	x100 Default: 100% of Nominal Current Range: IPROG_RESCALE_MIN to 125% of Nominal Current
93h	IPROG_RESCALE_PT1	-	R/W	2	Varies	x100 Default: 0.41V Range: IPROG_TURN_ON_POINT to 10V
94h	IPROG_RESCALE_PT2	-	R/W	2	Varies	x100 Default: 10V Range: IPROG_RESCALE_PT1 to 10V
95h	IPROG_TURN_ON_POINT	-	R/W	2	Varies	x100 Default: 0.41V Range: 0.41V to 10V
97h	VREF_MAX_LIMIT	-	R/W	2	Varies	x100 Default: 120% of Nominal Voltage Range: 5% to 120% of Nominal Voltage
98h	IREF_MAX_LIMIT	-	R/W	2	Varies	x100
99h	MODULE_VOUT_OV_FAULT_LIMIT_MULTIPLIER	-	R/W	2	Varies	x100 Default: 120 Range: 110 to 120
9Ah	MODULE_VOUT_OV_WARN_LIMIT_MULTIPLIER	-	R/W	2	Varies	x100 Default: 105 Range: 105 to 120
9Bh	MODULE_VOUT_UV_FAULT_LIMIT_MULTIPLIER	-	R/W	2	Varies	x100 Default: 85 Range: 80 to 90
9Ch	MODULE_VOUT_UV_WARN_LIMIT_MULTIPLIER	-	R/W	2	Varies	x100 Default: 90 Range: 80 to 95
9Dh	MODULE_OC_FAULT_LIMIT_MULTIPLIER	-	R/W	2	Varies	x100 Default: 105 Range: 10 to 105
9Eh	CV_LIMIT	-	R/W	2	Varies	x100 Default: Nominal Voltage Range: 5% to 120% of Nominal Voltage
A4h	MODULE_POWER_GOOD_ON	-	R/W	2	Varies	x100
A6h	MODULE_POWER_GOOD_OFF	-	R/W	2	Varies	x100
A8h	MODULE_VOLTAGE_RISE_SETTING	-	R/W	2	Varies	x1 Default: 20 Range: 20 to 100

SECTION 6 MODBUS SPECIFICATIONS

The NP08 Module Supported MODBUS Command List

Command Code	Command Name	Default Value	Access Type	Data Bytes	Data Format	Description
A9h	MODULE_CURRENT_RISE_SETTING	-	R/W	2	Varies	x1 Default: 20 Range: 20 to 100
ACh	MODULE_IO_ACTIVE_LEVEL_LOGIC	-	R/W	2	Bitmapped	x100
	b15:2					
	b1 - POWER_GOOD_ACTIVE_LEVEL					0 - POWER_GOOD Active Level is Active High 1 - POWER_GOOD Active Level is Active Low
	b0 - M_INHIBIT_ACTIVE_LEVEL					0 - M_INHIBIT Active Level is Active High 1 - M_INHIBIT Active Level is Active Low
ADh	MODULE_LOAD_TYPE	-	R/W	2	Varies	0x01 - Resistive (default) 0x02 - LED 0x03 - Capacitive
B0h	MODULE_READ_VOUT	-	R	2	Varies	x100
B1h	MODULE_READ_IOUT	-	R	2	Varies	x100
B2h	MODULE_READ_POUT	-	R	2	Varies	x100
B7h	MODULE_TEMP1-SYNC	-	R	2	Varies	x100
B8h	MODULE_TEMP2-BUCK	-	R	2	Varies	x100
B9h	MODULE_TEMP3-FWL	-	R	2	Varies	x100
BAh	MODULE_TEMP4-AMBIENT	-	R	2	Varies	x100
D0h	STATUS_SUMMARY		R	2	Bitmapped	
	b15:4					
	b3 - CONTROL_CC_MODE					Control is in CC mode (1) Control is in CV mode (0)
	b2 - MODULE_STATE					Asserts when module output is OFF due to the following reasons: - M_Inhibit - PSKILL - Invalid module address - VIPROG is turned off Module is OFF (1) Module is ON (0)
	b1 - AUTO_RECOVERABLE_FAULT					Asserts when any of the following faults are asserted: - Over Temperature Fault
	b0 - LATCH_TYPE_FAULT					Asserts when any of the following faults are asserted: - Over Voltage Fault - Under Voltage Fault - Over Current Fault - Fixed Input Under Voltage Fault - Remote Sense Short Circuit Fault - ISO Ton Max Fault - Buck Ton Max Fault - Short Circuit Fault

SECTION 6 COMMUNICATION BUS DESCRIPTIONS

6.4 Black Box

The power supply has the capability to store last faults and runtime information in non-volatile memory for failure analysis. Event data is saved to the Black Box for the following events.

1. Any events that caused the Module Output to shut down:
 - Module Output over voltage fault
 - Module Output over current fault
 - Module Output short circuit fault
 - Fan failure
 - Over temperature fault
2. Any events that caused the Boost to be Shut down:
 - Bulk short circuit fault
 - Bulk over voltage fault
 - Over temperature fault
3. Any events that caused the Standby to be Shut down:
 - Standby Output under voltage fault
 - Standby Output over voltage fault
 - Standby Output over current fault
 - Over temperature fault

The Black Box can be log again if there is a different event occurred.

Ex. The PSU shuts down due to Main Output over voltage protection, a Black Box event will be log.

The Black Box log history data stores up to 4 event data sets stored in a circular fashion with the latest index stored in the BLACKBOX_INDEX (0x4014 register). If the event data sets exceed 4, the oldest data set will be removed to give way for the latest data set (First In, First Out). Unused history data sets will have a value of zero for all registers.

This command is using MODBUS Function Read File Record. Each event data set is a file record containing 700 bytes.

SECTION 6 MODBUS SPECIFICATIONS

A power supply event data contains 700 bytes of data:

Record Number	MODBUS Address	Number of Bytes	Data Format	Description
1	0x5003	2	Bitmapped	ISO_SUPPLY_STATE
2	0x5004	2	Bitmapped	ISO_SUPPLY_STATUS
3	0x5005	2	Bitmapped	SIGNAL_STATE
4	0x5006	2	Bitmapped	SIGNAL_STATUS
5	0x5007	2	Bitmapped	STBY_STATE
6	0x5008	2	-	STBY_STATUS
7	0x5009	2	Bitmapped	G_ENABLE_STATE
8	0x500A	2	Bitmapped	G_ENABLE_STATUS
9	0x500B	2	-	FAN_STATE
10	0x500C	2	-	FAN_STATUS
11	0x500D	2	-	VFAN_TACHO1
12	0x500E	2	-	FAN_TACHO2
13	0x500F	2	x100	TEMP_AUX_ACTUAL
14	0x5010	2	x100	TEMP_AUX2_ACTUAL
15	0x5011	2	x100	TEMP_AMBIENT_ACTUAL
16-17	0x5012	4	x1	CURRENT_RUNTIME
18-19	0x5014	4	x1	TOTAL_RUNTIME
20	0x5016	2	Bitmapped	CASE_STATUS_WORD
21	0x5017	2	Bitmapped	CASE_STATUS_INPUT
22	0x5018	2	Bitmapped	CASE_STATUS_VOUT
23	0x5019	2	Bitmapped	CASE_STATUS_IOUT
24	0x501A	2	Bitmapped	CASE_STATUS_MFR_SPECIFIC
25	0x501B	2	Bitmapped	CASE_STATUS_TEMPERATURE
26	0x501C	2	Bitmapped	CASE_STATUS_CML
27	0x501D	2	-	PRI_ANALOG_STATUS
28	0x501E	2	-	PRI_INRUSH_STATE
29	0x501F	2	-	PRI_INRUSH_STATUS
30	0x5020	2	-	PRI_BULK_STATE
31	0x5021	2	-	PRI_BULK_STATUS
32	0x5022	2	x1	BULK_VSENSE_ACTUAL
33	0x5023	2	x100	BST_FET_TEMP1
34	0x5024	2	x100	BST_FET_TEMP2
35	0x5025	2	x100	LLC_TEMP1
36	0x5026	2	x100	LLC_TEMP2
37	0x5027	2	-	PRI_THERMAL_STATUS
38	0x5028	2	-	PMON_RAW_VIN
39	0x5029	2	-	PMON_RAW_IIN
40	0x502A	2	x100	MODULE1_VSENSE_RMT_ACTUAL
41	0x502B	2	x100	MODULE1_VSENSE_MAIN_ACTUAL
42	0x502C	2	x100	MODULE1_ISENSE_MAIN_ACTUAL
43	0x502D	2	-	MODULE1_ISO_VOUT_SENSE_RAW
44	0x502E	2	Bitmapped	MODULE1_SHUTDOWN_CAUSE
45	0x502F	2	Bitmapped	MODULE1_STATUS_INPUT
46	0x5030	2	Bitmapped	MODULE1_STATUS_WORD
47	0x5031	2	Bitmapped	MODULE1_STATUS_VOUT

SECTION 6 MODBUS SPECIFICATIONS

Record Number	MODBUS Address	Number of Bytes	Data Format	Description
48	0x5032	2	Bitmapped	MODULE1_STATUS_IOUT
49	0x5033	2	Bitmapped	MODULE1_STATUS_TEMPERATURE
50	0x5034	2	x100	MODULE2_VSENSE_RMT_ACTUAL
51	0x5035	2	x100	MODULE2_VSENSE_MAIN_ACTUAL
52	0x5036	2	x100	MODULE2_ISENSE_MAIN_ACTUAL
53	0x5037	2	-	MODULE2_ISO_VOUT_SENSE_RAW
54	0x5038	2	x100	MODULE2_SHUTDOWN_CAUSE
55	0x5039	2	x1	MODULE2_STATUS_INPUT
56	0x503A	2	x100	MODULE2_STATUS_WORD
57	0x503B	2	x1	MODULE2_STATUS_VOUT
58	0x503C	2	x100	MODULE2_STATUS_IOUT
59	0x503D	2	x100	MODULE2_STATUS_TEMPERATURE
60	0x503E	2	x100	MODULE3_VSENSE_RMT_ACTUAL
61	0x503F	2	x100	MODULE3_VSENSE_MAIN_ACTUAL
62	0x5040	2	x100	MODULE3_ISENSE_MAIN_ACTUAL
63	0x5041	2	x100	MODULE3_ISO_VOUT_SENSE_RAW
64	0x5042	2	x100	MODULE3_SHUTDOWN_CAUSE
65	0x5043	2	x1	MODULE3_STATUS_INPUT
66	0x5044	2	x1	MODULE3_STATUS_WORD
67	0x5045	2	x100	MODULE3_STATUS_VOUT
68	0x5046	2	x100	MODULE3_STATUS_IOUT
69	0x5047	2	Bitmapped	MODULE3_STATUS_TEMPERATURE
70	0x5048	2	x100	MODULE4_VSENSE_RMT_ACTUAL
71	0x5049	2	x100	MODULE4_VSENSE_MAIN_ACTUAL
72	0x504A	2	x100	MODULE4_ISENSE_MAIN_ACTUAL
73	0x504B	2	-	MODULE4_ISO_VOUT_SENSE_RAW
74	0x504C	2	Bitmapped	MODULE4_SHUTDOWN_CAUSE
75	0x504D	2	Bitmapped	MODULE4_STATUS_INPUT
76	0x504E	2	Bitmapped	MODULE4_STATUS_WORD
77	0x504F	2	Bitmapped	MODULE4_STATUS_VOUT
78	0x5050	2	Bitmapped	MODULE4_STATUS_IOUT
79	0x5051	2	Bitmapped	MODULE4_STATUS_TEMPERATURE
80	0x5052	2	x100	MODULE5_VSENSE_RMT_ACTUAL
81	0x5053	2	x100	MODULE5_VSENSE_MAIN_ACTUAL
82	0x5054	2	x100	MODULE5_ISENSE_MAIN_ACTUAL
83	0x5055	2	-	MODULE5_ISO_VOUT_SENSE_RAW
84	0x5056	2	Bitmapped	MODULE5_SHUTDOWN_CAUSE
85	0x5057	2	Bitmapped	MODULE5_STATUS_INPUT
86	0x5058	2	Bitmapped	MODULE5_STATUS_WORD
87	0x5059	2	Bitmapped	MODULE5_STATUS_VOUT
88	0x505A	2	Bitmapped	MODULE5_STATUS_IOUT
89	0x505B	2	Bitmapped	MODULE5_STATUS_TEMPERATURE
90	0x505C	2	x100	MODULE6_VSENSE_RMT_ACTUAL
91	0x505D	2	x100	MODULE6_VSENSE_MAIN_ACTUAL

SECTION 6 MODBUS SPECIFICATIONS

Record Number	MODBUS Address	Number of Bytes	Data Format	Description
92	0x505E	2	x100	MODULE6_ISENSE_MAIN_ACTUAL
93	0x505F	2	x100	MODULE6_ISO_VOUT_SENSE_RAW
94	0x5060	2	x100	MODULE6_SHUTDOWN_CAUSE
95	0x5061	2	x1	MODULE6_STATUS_INPUT
96	0x5062	2	x100	MODULE6_STATUS_WORD
97	0x5063	2	x1	MODULE6_STATUS_VOUT
98	0x5064	2	x100	MODULE6_STATUS_IOUT
99	0x5065	2	x100	MODULE6_STATUS_TEMPERATURE
100	0x5066	2	x100	MODULE7_VSENSE_RMT_ACTUAL
101	0x5067	2	x100	MODULE7_VSENSE_MAIN_ACTUAL
102	0x5068	2	x100	MODULE7_ISENSE_MAIN_ACTUAL
103	0x5069	2	x100	MODULE7_ISO_VOUT_SENSE_RAW
104	0x506A	2	x100	MODULE7_SHUTDOWN_CAUSE
105	0x506B	2	x1	MODULE7_STATUS_INPUT
106	0x506C	2	x1	MODULE7_STATUS_WORD
107	0x506D	2	x100	MODULE7_STATUS_VOUT
108	0x506E	2	x100	MODULE7_STATUS_IOUT
109	0x506F	2	Bitmapped	MODULE7_STATUS_TEMPERATURE
110	0x5070	2	x100	MODULE8_VSENSE_RMT_ACTUAL
111	0x5071	2	x100	MODULE8_VSENSE_MAIN_ACTUAL
112	0x5072	2	x100	MODULE8_ISENSE_MAIN_ACTUAL
113	0x5073	2	-	MODULE8_ISO_VOUT_SENSE_RAW
114	0x5074	2	Bitmapped	MODULE8_SHUTDOWN_CAUSE
115	0x5075	2	Bitmapped	MODULE8_STATUS_INPUT
116	0x5076	2	Bitmapped	MODULE8_STATUS_WORD
117	0x5077	2	Bitmapped	MODULE8_STATUS_VOUT
118	0x5078	2	Bitmapped	MODULE8_STATUS_IOUT
119	0x5079	2	Bitmapped	MODULE8_STATUS_TEMPERATURE

SECTION 7 APPLICATION NOTES

7.1 Mode of Operation

The power supply is configurable as four types of source, DVS (Digital Voltage Source), DCS (Digital Current Source), AVS (Analog Voltage Source), ACS (Analog Current Source). Operation OFF is required before changing the output mode configuration.

The operation mode can be configured with 0x87 MODULE_CONFIG command under specific module, or tick the detailed mode in the GUI directly.

Operation Mode	0x87 Command Value	Condition
DVS + CC Mode	00000000 00000011	Regulated at different load
DVS + Latch Mode	00000000 00000111	
DCS + CC Mode	00000000 00000001	CR mode e-load is required for current source mode.
DCS + Latch Mode	00000000 00000101	
AVS + CC Mode	00000000 00000010	External DC voltage source is needed for Analog Mode, Supply 0-5 or 0-10 on the VI_Prog Pin of the module. CR mode e-load is required for current source mode.
AVS + Latch Mode	00000000 00000110	
ACS + CC Mode	00000000 00000000	
ACS + Latch Mode	00000000 00000100	

Different Module Variant

If new module variant is plugged in to case, it is a must to bring back the configuration to default setting by going to Details > Case > Configuration. Change Module Config Valid from “Case Internal Memory” to “Internal Default” and Save Update to Case. All the modules plugged in will go back to its default config. The next AC turn on is expected to be at module operation off again, perform new configuration to turn on and save the latest configuration.

The screenshot shows the 'Case Details' configuration page for device NP08W1A. The 'Configuration' tab is active. In the 'Module Config Valid' dropdown menu, 'Internal Default' is selected, and this dropdown is highlighted with a red box. In the left sidebar, the 'Details' menu item is also highlighted with a red box. The main configuration area includes fields for Device Address (C0), Baud Rate Configuration (115200), Fan Speed Override (0%), and Case Programmable Hold (0 mSec). Below these are IO Polarity settings for PGOOD and ACOK. A table lists Module Groups 1 through 8 with VREF and IREF values. At the bottom, there is a 'Ready to Configure' status and buttons for 'Refresh Read', 'Start Update', and 'Save Update to Case'.

SECTION 7 APPLICATION NOTES

7.2 Output Adjustability and Programmability

Output Programming via Analog 0-5V and 0-10V

Applicable for both Voltage Source and Current Source mode operation. The table below is for reference only.

Voltage Source Mode (Output Voltage Programming)

0-5V_PROG (V)	0-10V_PROG (V)	Expected Output Voltage (V)
0	0	OFF
0.208	0.416	5% of Vnom
0.500	1.000	12% of Vnom
1.000	2.000	24% of Vnom
1.500	3.000	36% of Vnom
2.000	4.000	48% of Vnom
2.500	5.000	60% of Vnom
3.000	6.000	72% of Vnom
3.500	7.000	84% of Vnom
4.000	8.000	96% of Vnom
4.500	9.000	108% of Vnom
5.000	10.000	120% of Vnom

Current Source Mode (Output Current Programming)

0-5V_PROG (V)	0-10V_PROG (V)	Expected Output Current (A)
0	0	OFF
0.208	0.416	5.2% of Irated
0.500	1.000	12.5% of Irated
1.000	2.000	25.0% of Irated
1.500	3.000	37.5% of Irated
2.000	4.000	50.0% of Irated
2.500	5.000	62.5% of Irated
3.000	6.000	75.0% of Irated
3.500	7.000	87.5% of Irated
4.000	8.000	100.0% of Irated
4.500	9.000	112.5% of Irated
5.000	10.000	125.0% of Irated

SECTION 7 APPLICATION NOTES

Vprog and Iprog Rescaling

This section describes the analog Vprog and Iprog rescaling function of the PSU and corresponding rescale profiles.

Note: The rescaling function is also applicable for the 0-5V PROG, just factor-in a multiplying factor of 0.5 since all the discussions below are referenced to the 0-10V PROG.

Vprog Rescaling

The PSU's mode of operation must be on Analog Voltage Source (AVS) mode when MODULE_CONFIG (command code 87h) is set to 02h. The PSU should be on standby mode when adjusting Vprog rescale profile.

Vprog Rescaling Default Profile

This describes the setting for analog Vprog default profile. Writing 02h (default) to DSP_PROG_RESCALE_PROFILE (command code 8Bh) will update the Vprog profile to default. This profile will set target voltage from 0V (OFF) to 120% of Vnom for 0-10V Vprog respectively.

PSU target voltage versus the 0-10V Vprog for Vprog rescale default profile.

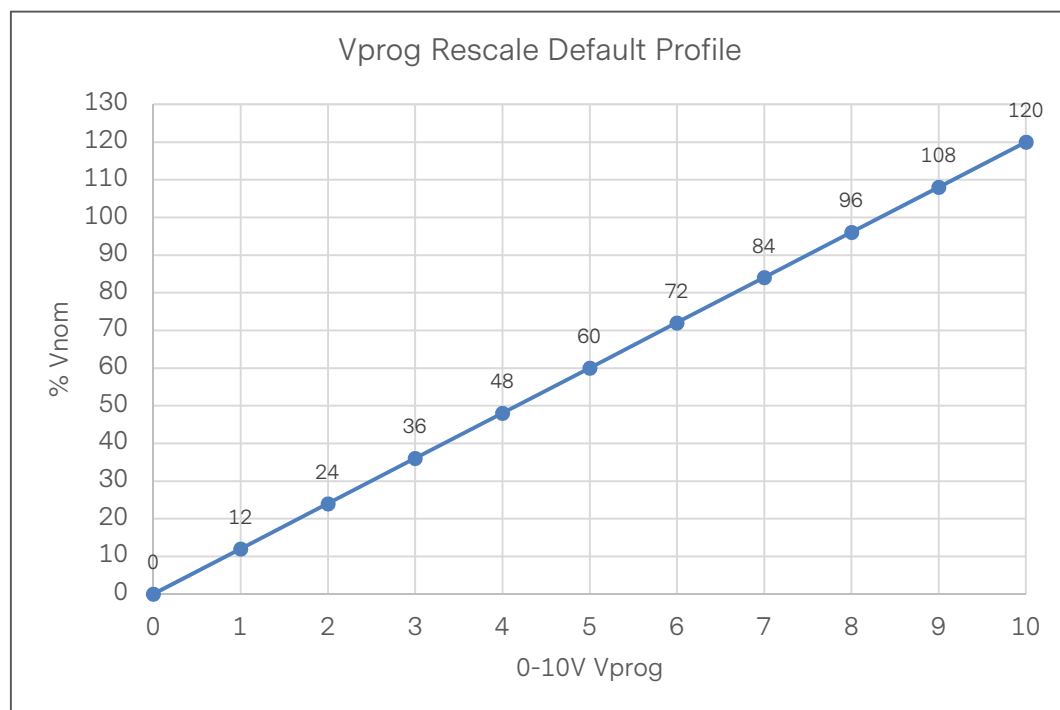

SECTION 7 APPLICATION NOTES

Vprog Rescaling Profile 1

The following sequence of commands should be followed to set Vprog Profile 1:

1. Set VPROG_RESCALE_MIN (command code 8Ch) to adjust the minimum rescale value.
2. Set VPROG_RESCALE_MAX (command code 8Fh) to adjust to adjust the maximum rescale value.
3. Set DSP_PROG_RESCALE_PROFILE (command code 8Bh) to 00h (profile 1) to update the Vprog profile based on the written values from the rescale commands.

Sample Vprog rescale profile 1 adjustment is shown below, VPROG_RESCALE_MIN is set to 40% Vnom, and VPROG_RESCALE_MAX is set to 100% Vnom.

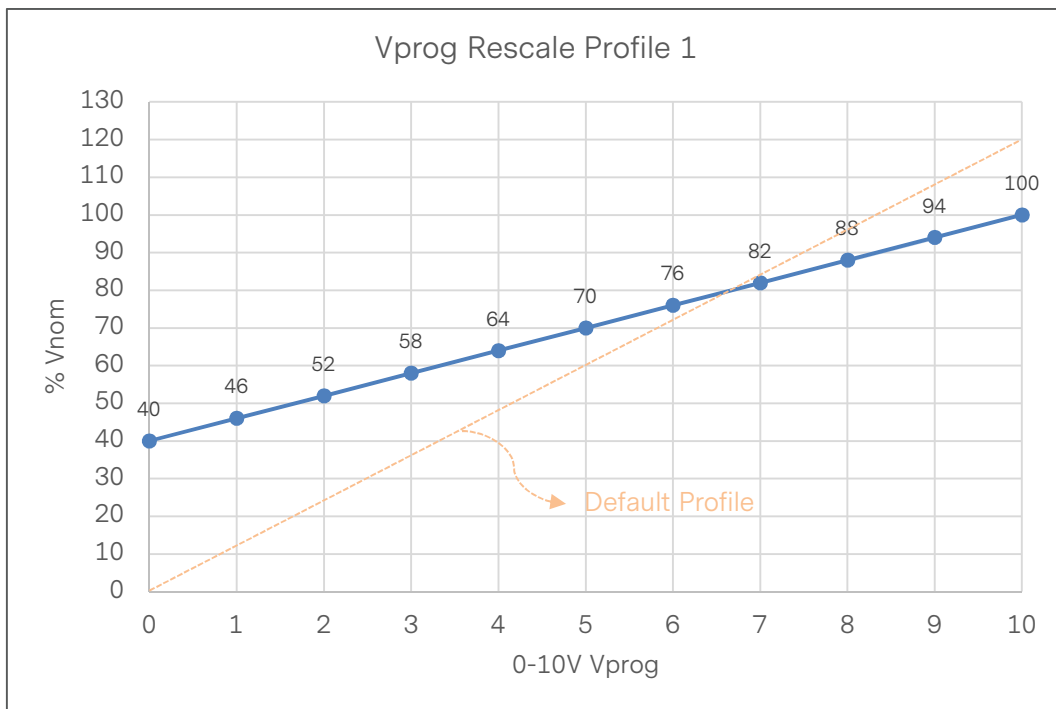

Note: VPROG_RESCALE_MIN must be less than VPROG_RESCALE_MAX.

SECTION 7 APPLICATION NOTES

Vprog Rescaling Profile 2

The following sequence of commands should be followed to set Vprog Profile 2:

1. Set VPROG_RESCALE_PT1 (command code 8Eh) to adjust the Vprog Low Point.
2. Set VPROG_RESCALE_PT2 (command code 8Fh) to adjust the Vprog High Point.
3. Set DSP_PROG_RESCALE_PROFILE (command code 8Bh) to 01h (profile 2) to update the Vprog profile based on the written values from the rescale commands.

Sample Vprog rescale profile 2 adjustment is shown below, VPROG_RESCALE_PT1 is set to 200 (2V), and VPROG_RESCALE_PT2 is set to 800 (8V).

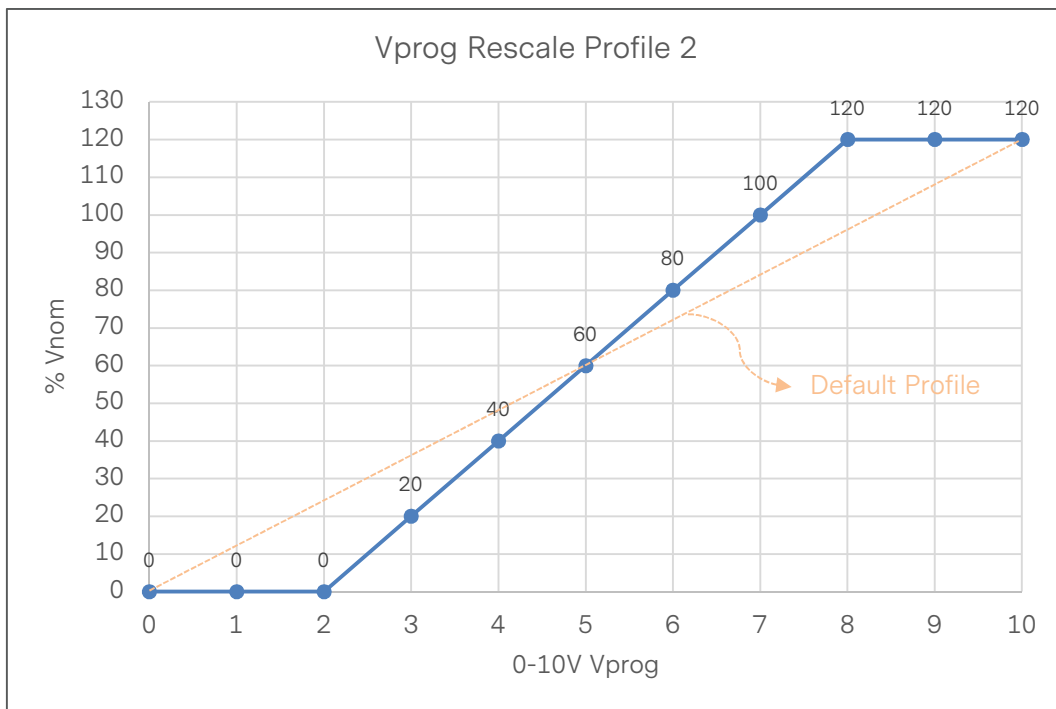

Note: VPROG_RESCALE_PT1 must be less than VPROG_RESCALE_PT2.

SECTION 7 APPLICATION NOTES

Vprog Rescaling Profile 3

The following sequence of commands should be followed to set Vprog Profile 3:

1. Set VPROG_TURN_ON_POINT (command Code 90h) to adjust Vprog Turn on Point.
2. Set VPROG_RESCALE_PT1 (command code 8Eh) to adjust the Vprog Low Point.
3. Set VPROG_RESCALE_PT2 (command code 8Fh) to adjust the Vprog High Point.
4. Set DSP_PROG_RESCALE_PROFILE (command code 8Bh) to 02h (profile 3) to update the Vprog profile based on the written values from the rescale commands.

Sample Vprog rescale profile 3 adjustment is shown below, VPROG_TURN_ON_POINT is set to 100 (1V), VPROG_RESCALE_PT1 is set to 200 (2V), and VPROG_RESCALE_PT2 is set to 800 (8V).

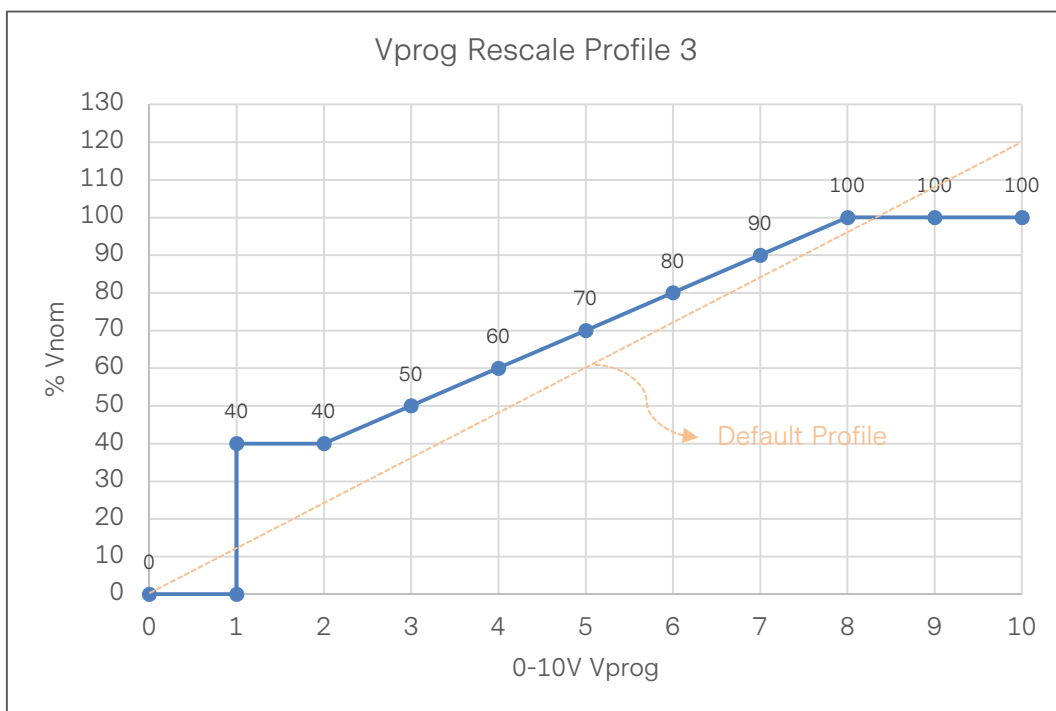

Note: VPROG_TURN_ON_POINT must be less than VPROG_RESCALE_PT1, and VPROG_RESCALE_PT1 must be less than VPROG_RESCALE_PT2.

SECTION 7 APPLICATION NOTES

Iprog Rescaling

The PSU's mode of operation must be on Analog Current Source (ACS) mode when MODULE_CONFIG (command code 87h) is set to 00h. The PSU should be on standby mode when adjusting Iprog rescale profile.

Iprog Rescaling Default Profile

This describes the setting for analog Iprog default profile. Writing 02h (default) to DSP_PROG_RESCALE_PROFILE (command code 8Bh) will update the Iprog profile to default. This profile will set target current to 0% to 100% for 0-10V Iprog respectively.

PSU target Current versus the 0-10V Iprog for Iprog rescale default profile.

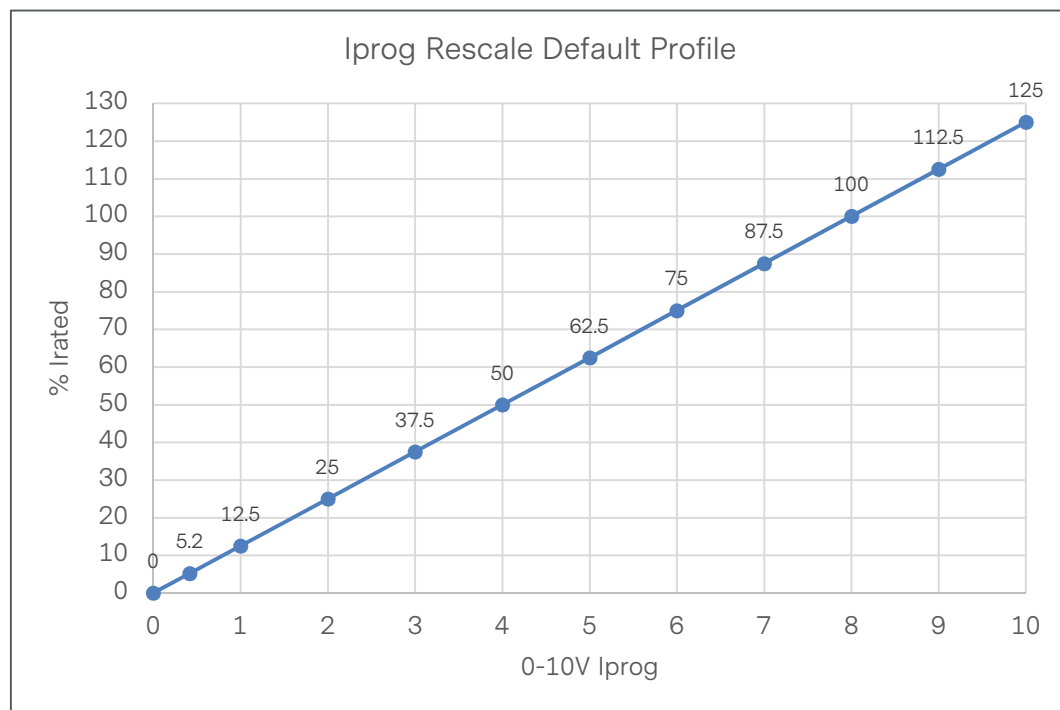

SECTION 7 APPLICATION NOTES

Iprog Rescaling Profile 1

The following sequence of commands should be followed to set Iprog Profile 1:

1. Set IPROG_RESCALE_MIN (command code 91h) to adjust the minimum rescale value.
2. Set IPROG_RESCALE_MAX (command code 92h) to adjust to adjust the maximum rescale value.
3. Set DSP_PROG_RESCALE_PROFILE (command code 8Bh) to 00h (profile 1) to update the Iprog profile based on the written values from the rescale commands.

Sample Iprog rescale profile 1 adjustment is shown below. This profile can set the target output current from 40% to 100% of Irated for 0V to 10V IPROG.

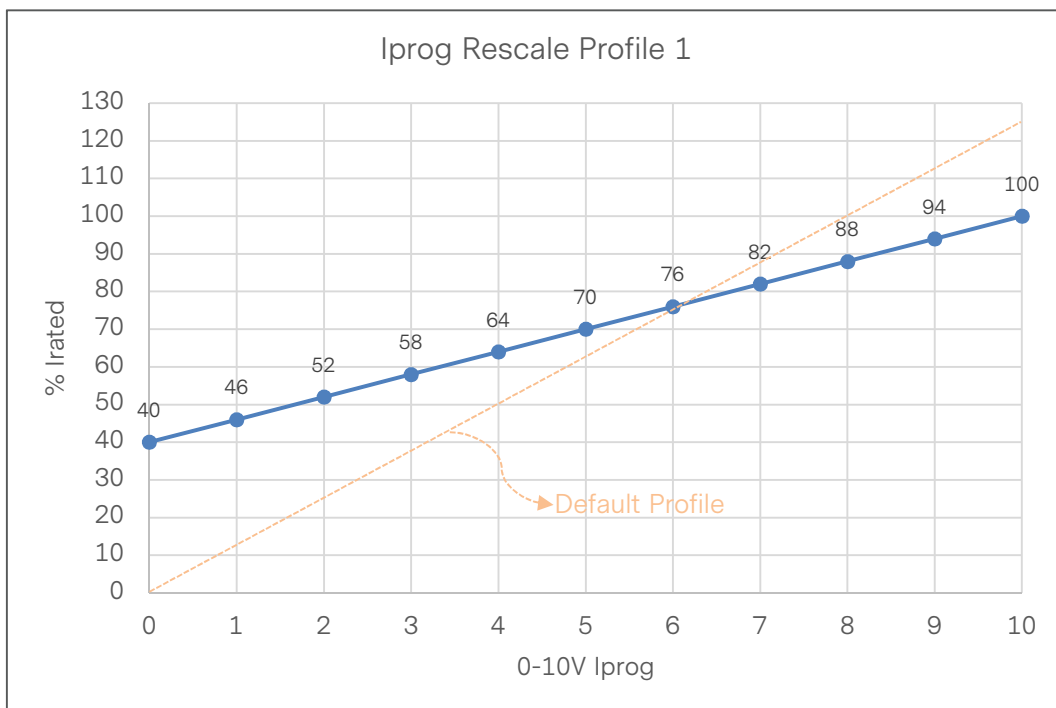

Note: IPROG_RESCALE_MIN must be less than IPROG_RESCALE_MAX.

SECTION 7 APPLICATION NOTES

Iprog Rescaling Profile 2

The following sequence of commands should be followed to set Iprog Profile 2:

1. Set IPROG_RESCALE_PT1 (command code 93h) to adjust the Iprog Low Point.
2. Set IPROG_RESCALE_PT2 (command code 94h) to adjust the Iprog High Point.
3. Set DSP_PROG_RESCALE_PROFILE (command code 8Bh) to 01h (profile 2) to update the Iprog profile based on the written values from the rescale commands.

Sample Iprog rescale profile 2 adjustment is shown below, IPROG_RESCALE_PT1 is set to 200 (2V), and IPROG_RESCALE_PT2 is set to 800 (8V).

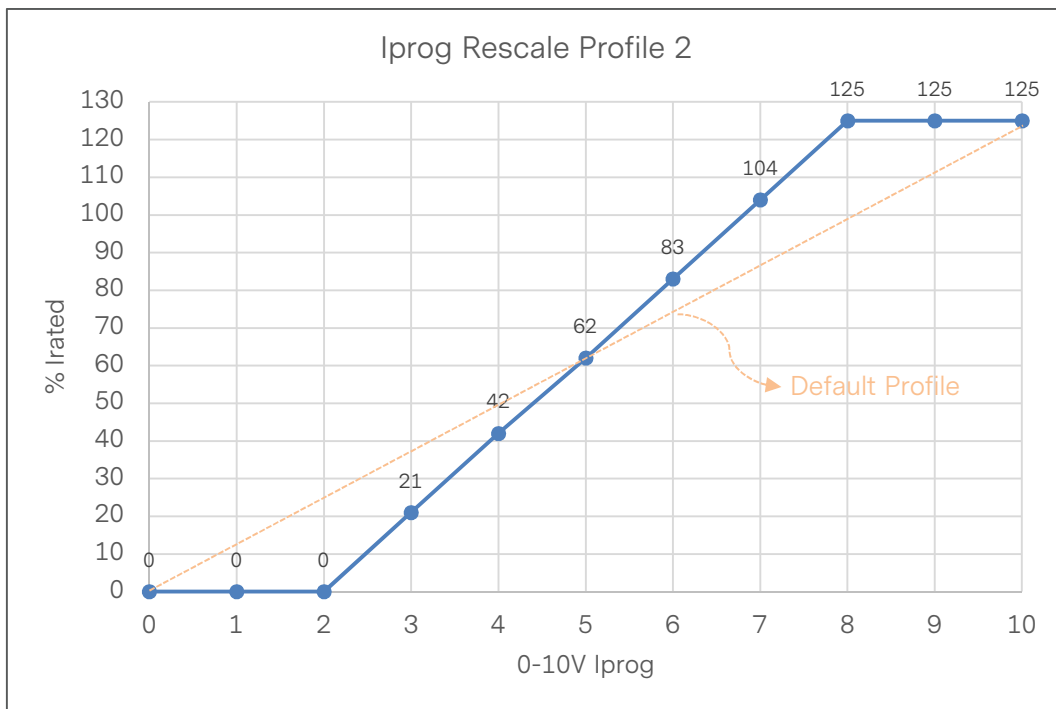

Note: IPROG_RESCALE_PT1 must be less than IPROG_RESCALE_PT2.

SECTION 7 APPLICATION NOTES

Iprog Rescaling Profile 3

The following sequence of commands should be followed to set Vprog Profile 3:

1. Set IPROG_TURN_ON_POINT (command Code 95h) to adjust Iprog Turn on Point.
2. Set IPROG_RESCALE_PT1 (command code 93h) to adjust the Iprog Low Point.
3. Set IPROG_RESCALE_PT2 (command code 94h) to adjust the Iprog High Point.
4. Set DSP_PROG_RESCALE_PROFILE (command code 8Bh) to 02h (profile 3) to update the Iprog profile based on the written values from the rescale commands.

Sample Iprog rescale profile 3 adjustment is shown below, IPROG_TURN_ON_POINT is set to 100 (1V), IPROG_RESCALE_PT1 is set to 200 (2V), and IPROG_RESCALE_PT2 is set to 800 (8V).

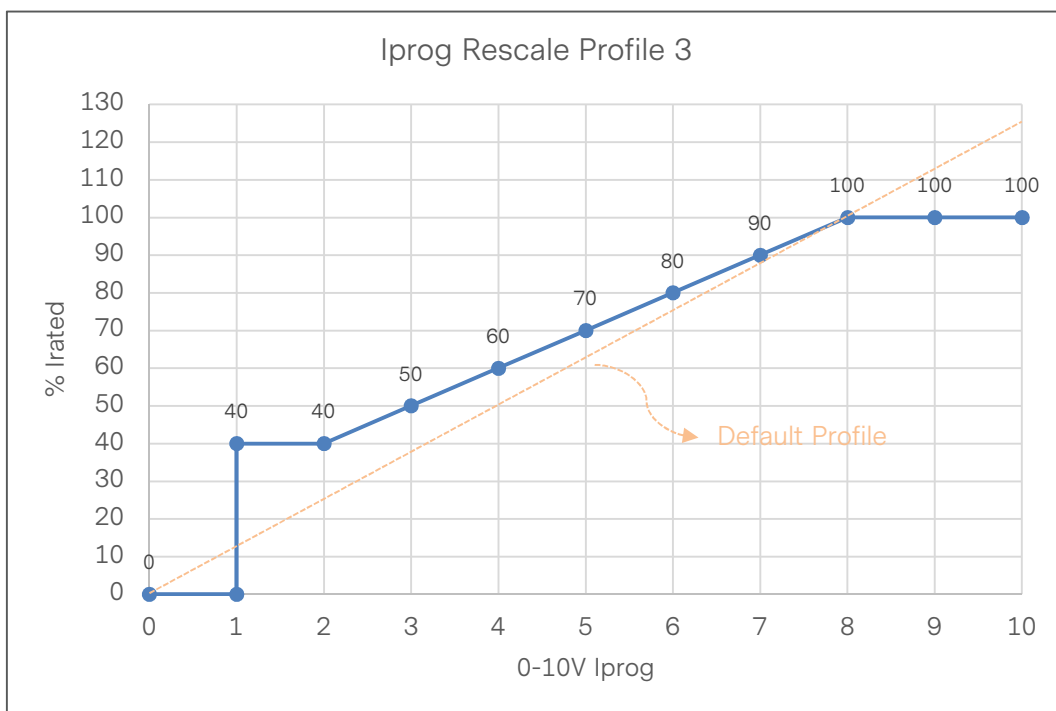

Note: IPROG_TURN_ON_POINT must be less than IPROG_RESCALE_PT1, and IPROG_RESCALE_PT1 must be less than IPROG_RESCALE_PT2.

SECTION 7 APPLICATION NOTES

7.3 Current Sharing

The NP08 series' main output is equipped with current sharing capability. This will allow up to 8 modules to be connected in parallel in 1 rack, however inter-case is not supported.

The current sharing error is as below.

Percent Load per Module (%)	Current Sharing Error (%)
10	Fix error of 10% I _{rated}
20	Fix error of 10% I _{rated}
30	±10%
40	±10%
50	±5%
60	±5%
70	±5%
80	±5%
90	±5%
100	±5%

The NP08 modules don't have built in OR'ing protection. External OR-ing diodes are recommended in a redundant parallel system. For good regulation the remote sense wires must be connected at the busbar point. Typical connection diagram is as below.

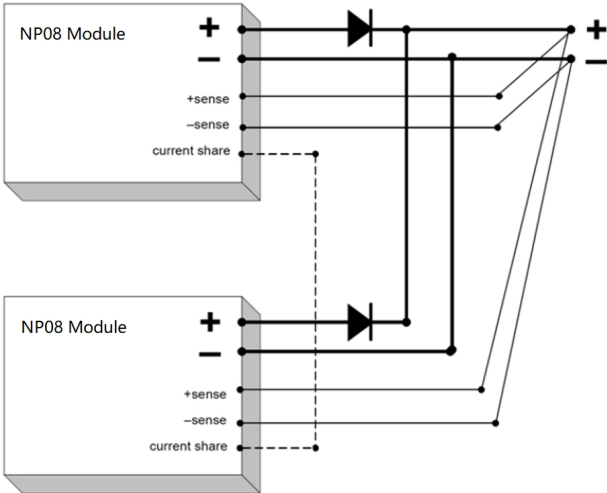

SECTION 7 APPLICATION NOTES

7.4 Output Ripple and Noise Measurement

The setup outlined in the diagram below has been used for output voltage ripple and noise measurements on the NP08 series power supply. When measuring output ripple and noise, a scope jack in parallel with a 0.1 μ F ceramic chip capacitor, and a 10 μ F tantalum capacitor will be used. Oscilloscope can be set to 20MHz bandwidth for this measurement.

For Differential Mode Ripple & Noise: POWER-to-RETURN

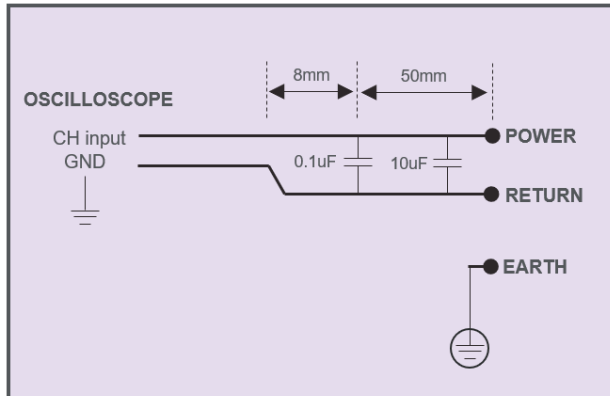

For Common Mode Ripple & Noise: POWER-to-EARTH

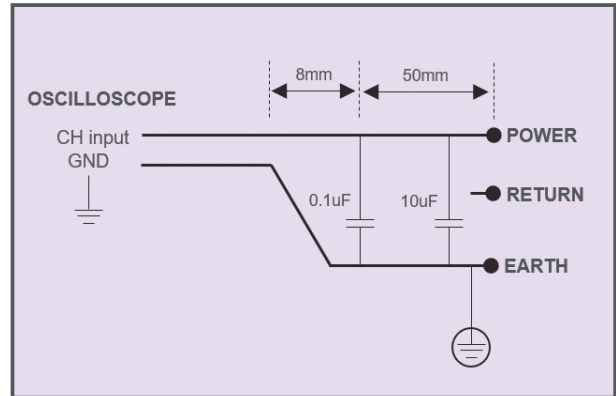

For Common Mode Ripple & Noise: RETURN-to-EARTH

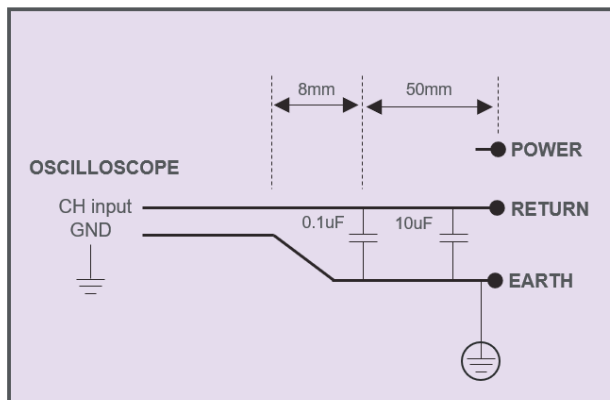

SECTION 8 RECORD OF REVISION AND CHANGES

Issue	Date	Description	Originators
1.0	11.13.2024	First Issue	A. Zhang
1.1	12.02.2025	Delete the 60V output voltage, and add note for the 48V module. Update description of G_ACOK, G_PGOOD, ISO_M_INHIBIT, ISO_POWER_GOOD. Update Device Address, D0h, Blackbox. Add the NP05 case and dual output module description.	A. Zhang



For international contact information,
visit advancedenergy.com.

powersales@aei.com (Sales Support)
productsupport.ep@aei.com (Technical Support)
+1 888 412 7832

ABOUT ADVANCED ENERGY

Advanced Energy (AE) has devoted more than four decades to perfecting power for its global customers. AE designs and manufactures highly engineered, precision power conversion, measurement and control solutions for mission-critical applications and processes.

Our products enable customer innovation in complex applications for a wide range of industries including semiconductor equipment, industrial, manufacturing, telecommunications, data center computing, and medical. With deep applications know-how and responsive service and support across the globe, we build collaborative partnerships to meet rapid technological developments, propel growth for our customers, and innovate the future of power.

PRECISION | POWER | PERFORMANCE | TRUST

Specifications are subject to change without notice. Not responsible for errors or omissions. ©2024 Advanced Energy Industries, Inc. All rights reserved. Advanced Energy®, and AE® are U.S. trademarks of Advanced Energy Industries, Inc.