

### Introduction

In this technical note, we provide detailed information on the connections, pins and leads for the UltraVolt M Series and V Series of microsize high voltage power supplies. This document augments the data sheet for each series. Complete data sheets can be found at [www.ultravolt.com](http://www.ultravolt.com).

The M and V Series microsize units deliver 0 to 600V through 0 to 1.5kV in a 1W miniature package. The input voltages available are  $12\pm 0.5\text{VDC}$ ,  $15\pm 0.5\text{VDC}$  and  $24\pm 1\text{VDC}$ , depending on output wattage.

While electrical specifications are identical, the M is a horizontal mount unit; the V is a vertical mount unit with a smaller PC board footprint.

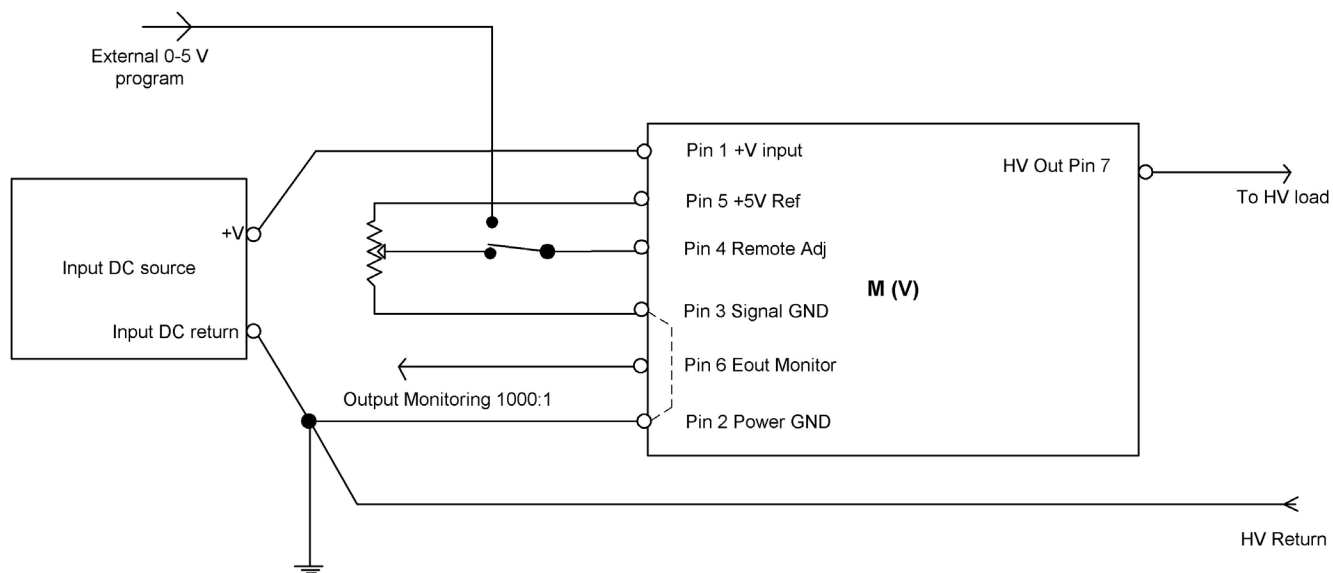

Figure 1: M and V Series Functional Diagram

### Connections Overview

#### Pin 1, Positive power input:

This pin is the positive power input (12, 15, or 24VDC) coming from the system AC/DC or DC/DC low-voltage power source. The input source must be capable of providing at least 120% of the maximum input current required by the M or V Series unit at full load (see [M Series](#) or [V Series datasheet](#) for more details).

#### Pin 2, Input Power Ground Return:

This pin is the return to the input DC source and is separate from the signal ground. Connection to this pin is also used in the system as the HV Return.

### **Pin 3, Signal Ground Return:**

This pin is used as return for the voltage control and voltage monitor signals. It is provided as a separate ground for low-voltage signals in order to avoid any interference with the High Voltage (HV) and Input Power returns. Do not use this pin as a direct connection to the HV Return.

### **Pin 4, Control Input:**

This pin allows the control of the high-voltage output by a low-voltage signal. Using a 0 to 5V  $\pm 0.5\%$  positive voltage, the high voltage can be controlled from 0 to 100%. The control 5V signal source can be a DAC, op amp, etc. or a voltage derived from the 5V internal reference (+5V Ref) via a potentiometer. For Pin 4, the input impedance is 1M. If a potentiometer is used in conjunction with the internal reference, we recommend values between 10k to 100k. The control voltage is positive in reference to signal ground for units with either output polarity (positive HV or negative HV).

### **Pin 5, Output Reference:**

A +5V  $\pm 0.5\%$  reference voltage with a temperature coefficient of 50ppm/ $^{\circ}\text{C}$  and 1mA maximum current is available. This reference voltage can be used to program the output voltage via an external potentiometer or a resistive divider.

### **Pin 6, Output Voltage Monitor:**

This pin provides a low-voltage proportional with the high-voltage output via 1000:1 divider (1V per 1kV output). For positive polarity units, the voltage monitor is positive in reference to return; for negative polarity outputs the monitor voltage is negative in reference to return. The grounded side of the divider has 200k  $\pm 1\%$  impedance. Please take this value into account when the voltage monitor is connected to a system with low input impedance. For example, if you are using a digital voltage meter (DVM) with 10M input impedance, the nominal error is about 2% (it would read 0.980V instead of 1V when the HV output is at 1000V). A 1M input impedance meter will give a nominal error of 16.7% (it would read 0.833V instead of 1V for HV output at 1000V). The divider is linear and proportional over the entire range; therefore the numerical error can be easily compensated in the system. We recommend the use of a high impedance buffer.

### **Pin 7, High Voltage Output:**

This is the high-voltage output (up to 1500V depending on the model). The pin is located farther away from the other six pins in order to provide the proper clearance for the high voltage. When designing the system PC board, the proper creepage and clearance spacing must be observed.

### **Flying Lead option:**

Instead of pin 7, M and V Series units can have the high-voltage output provided via a flying lead. (See option in the [datasheet](#)).

### **Case metal tabs:**

The M and V Series units are encapsulated in tinned steel cases with mounting tabs. The case and tabs are internally connected to the input power return. We recommend soldering the tabs to the system ground plane (See tab locations and dimension in the [datasheet](#)).